



www.johnsonhardware.com

INSTRUCTIONS

2610F SERIES WALL MOUNT OPEN POCKET SINGLE DOOR

FOR ONE 1-3/8" (35mm)
OR 1-3/4" (45mm)
DOOR UP TO 125 LBS.

- Prepare opening to dimensions shown (or if existing opening, size door to fit).
- Mount track to wall. Drill holes in upper flange of track at stud locations, or where a solid anchor is assured. TRACK MUST BE PERFECTLY LEVEL, or door will not stay in position. Fasten 1/2" (12.5mm) above header.
- Casing/Baseboard shim will be required behind track flange if Casing and Baseboard is applied around opening.
- Dismantle #12 Guide and fasten base to jamb at floor.
- Insert hanger wheels into track. Alternate 2 wheel side of hanger so that 3 wheels are on each track leg for even weight distribution. Measure 2" (50mm) in from each edge. Fasten hanger plates on center with #12 X 1-1/4" (32mm) pan head screws. Make sure both lock tabs are on the non-fascia side.

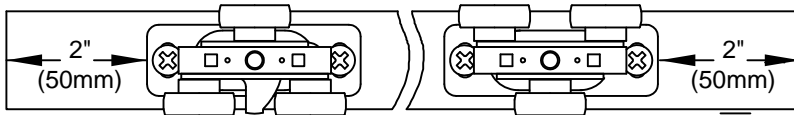

ALTERNATE WHEEL POSITIONS IN TRACK FOR EVEN WEIGHT DISTRIBUTION

- Hold door in opening and slip pivot pin into slot in door plate. When both pivots are seated, lock in place with locking tab. Reinsert front part of #12 Guide into base and move in until a slight clearance is obtained. Fasten Guide together with two screws.
- Position door over opening until desired closure is obtained and back edge of door is still in #12 Guide. Fasten one 1155 STOP to limit door travel. Open door until door is flush with jamb face and fasten other 1155 STOP to limit opening travel of door.

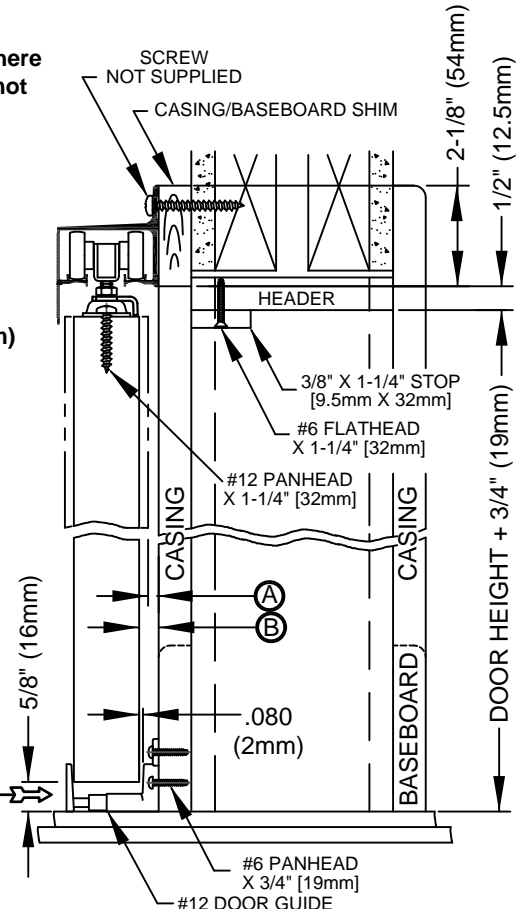
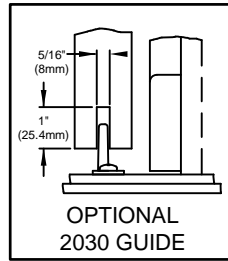

- Ⓐ GAP BETWEEN 1-3/4" (45mm) DOOR AND CASING IS 1/4" (6.4mm)
- Ⓑ GAP BETWEEN 1-3/8" (35mm) DOOR AND CASING IS 7/16" (11mm)

- Drill door 36" (914mm) from floor to fit pulls, and install.
- Trim around opening as desired.
- Attach 3/8" X 1-1/4" (9.5mm X 32mm) stop (not included) at edge of header with #6 X 1-1/4" (32mm) flat head screws.
- If required for alignment, adjust hangers with wrench.
- Snap on 2680 Endcaps.

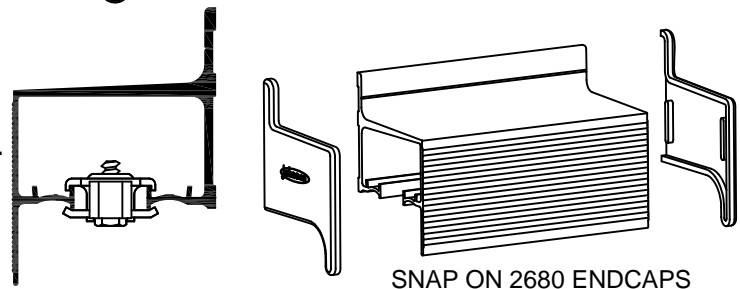

SNAP ON 2680 ENDCAPS

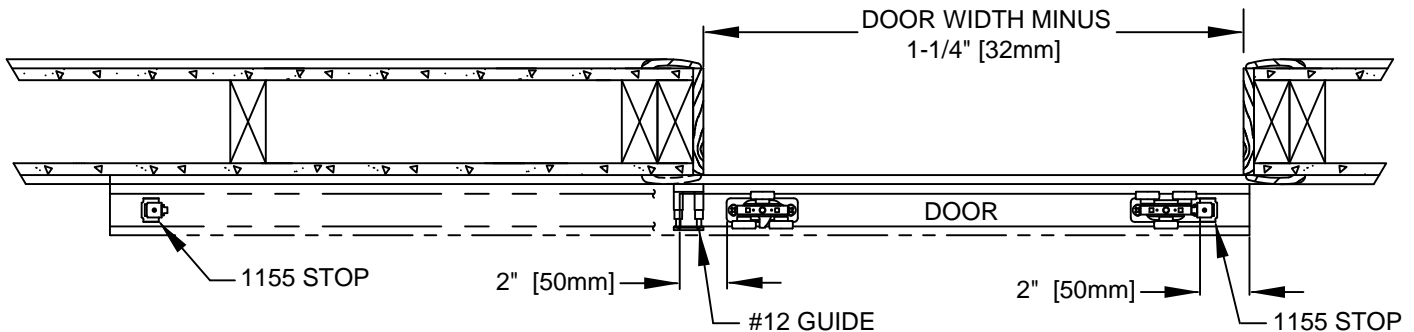

PLEASE CALL 1-800-837-5664 IF PARTS ARE MISSING / DO NOT RETURN TO PLACE OF PURCHASE



www.johnsonhardware.com

INSTRUCTIONS

2610F SERIES VALANCE & JAMB PROFILE

