

Eclipse Architectural®

Exterior folding door systems

E3™ Hardware Installation Instructions &

E3™ System Installation Manual

DS Group®

www.theDSgroup.com

Tomorrow's Innovative Solutions for Today's Doors & Windows

The DS Group Of Companies : Draftseal®, Kristrack®, Eclipse Architectural® & DSD Hardware

E3™ Hardware Installation Instructions & E3™ System Installation Manual

Hardware, Track, Sill System and Weathersealing for Exterior Folding Doors

Note to Eclipse Door Fabricator:

Please attach this E3 Installation Instruction Sheet to door before shipping to job site

Thank you for choosing the Eclipse Architectural hardware system for exterior folding doors. The hardware, made with great care, if installed correctly will provide years of trouble-free operation.

The following instructions provide guidelines for measuring and fitting the suspended folding doors complete with the Eclipse E3™ Hardware System.

While this guide is as comprehensive as possible, it cannot address all eventualities, which may be encountered on site. Regardless of the quality of the hardware or construction of the panels, the most important criteria for a successful job are :

- Level, flat rough floor
- Square rough opening
- Structurally sound and unyielding rough opening header
- Clean door assembly tracks

NOTE: Eclipse Architectural is unable, and does not control, the actual site measuring and installation of the doors or hardware, and therefore does not assume any responsibility for the performance of the installed product.

The instructions below should be followed and adhered to. The provided below step-by-step instructions can assist any fabricator or installer. Installation is best done with more than one person.

Thank you for choosing hardware, track, sill and weatherseal products by Eclipse Architectural.

System Specifications

In a single direction

Maximum Door Weight: 220 lbs (100 kg)

Maximum Door Width: 39" (990 mm)

Maximum Door Height: 120" (3048 mm)

Door Thickness: 1-3/4" or 2-1/4" (44.45 or 57.15mm) when using E3 Sill System. 1-3/8" (34.93mm) to 3" (76.2mm) when using floor channel.

Maximum Number of Doors: 8 each way

NO SCALE

E3™ HARDWARE Installation Instructions

Wall Pivots

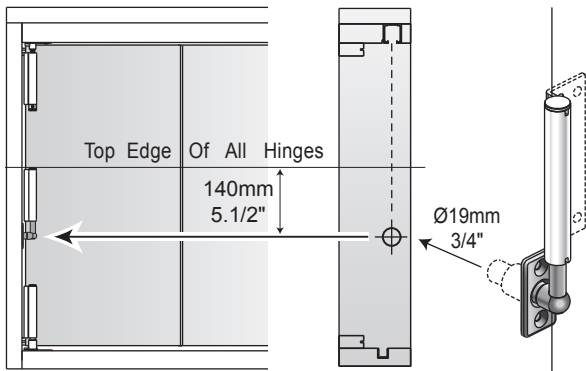

Perimeter Seal

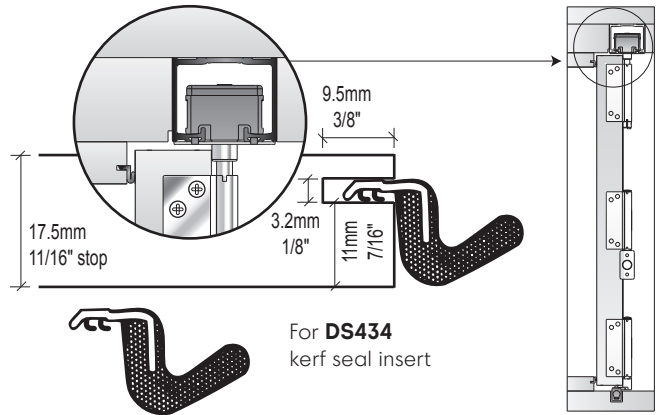

Panel Orientation

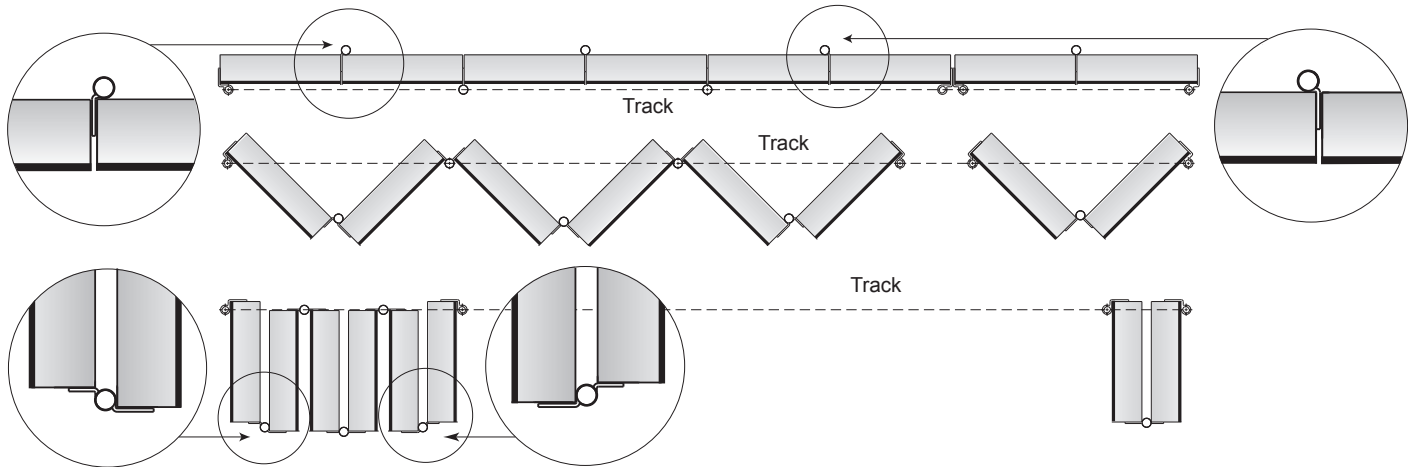

Eclipse Warranty

The Eclipse program is a complete product offering. Component deletions and/or substitutions are strictly prohibited. Warranty is void if system has missing or substitute products. Please refer to www.dsgroup.com/terms for our full warranty information, terms & conditions, returns & allowances, claims policy, and other general information.

NO SCALE

Hinges

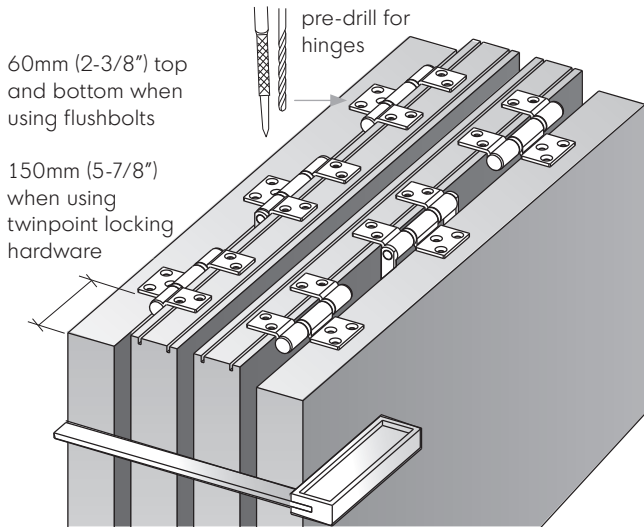

Carriers & Guides

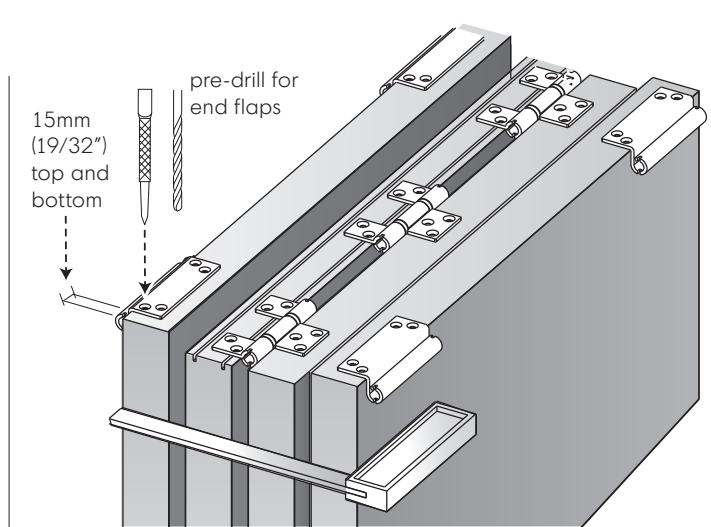

Assembly - Reversible

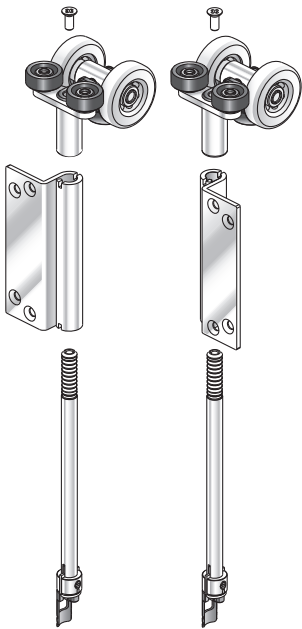

Installation

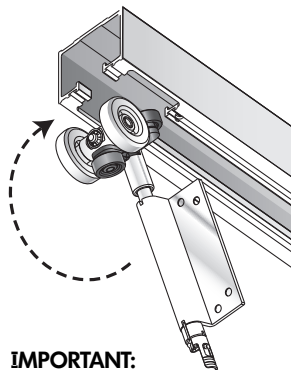

IMPORTANT:
Thoroughly clean inside track.

Hardware Orientation

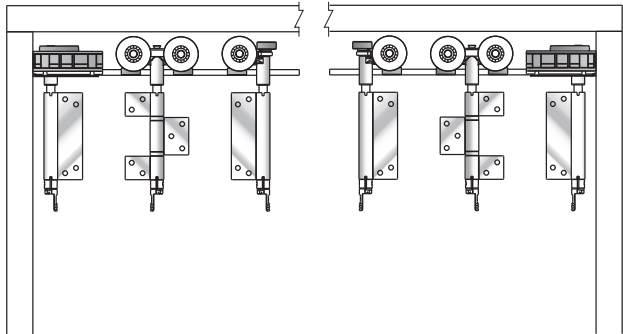

Top Pivot Block

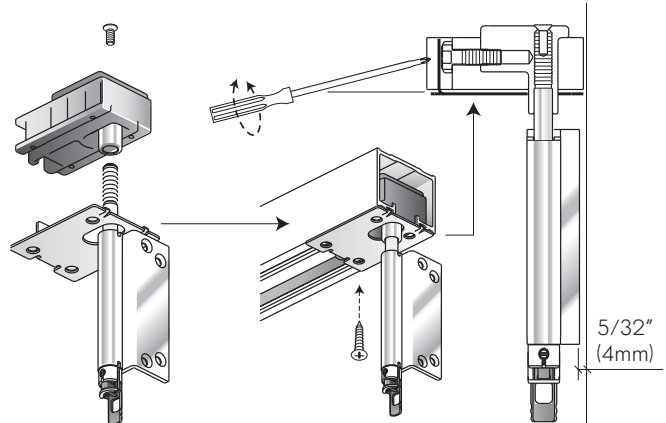

NO SCALE

Bottom Pivot Block

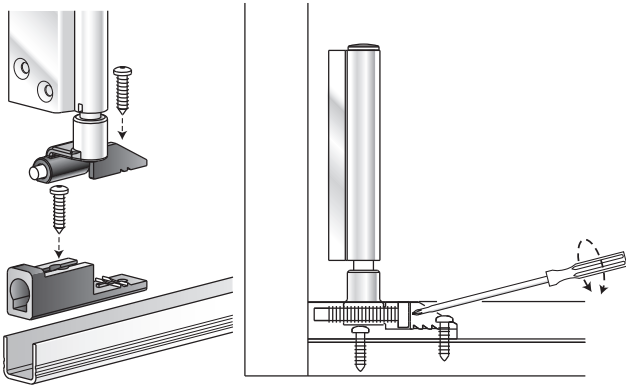

Fitting Pivot Panel

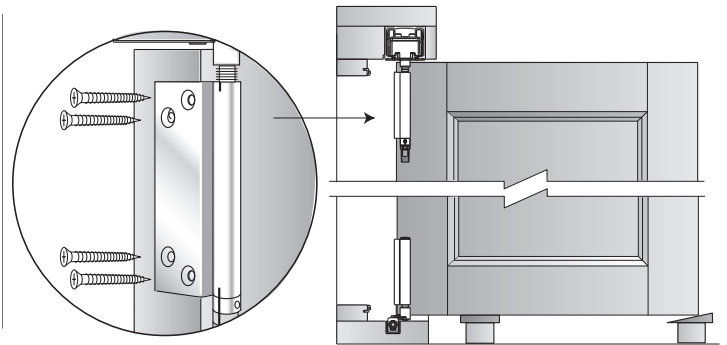

Panel Adjustment

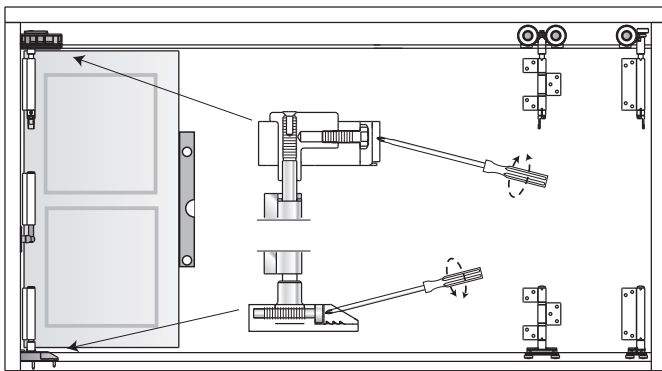

Adding Panels

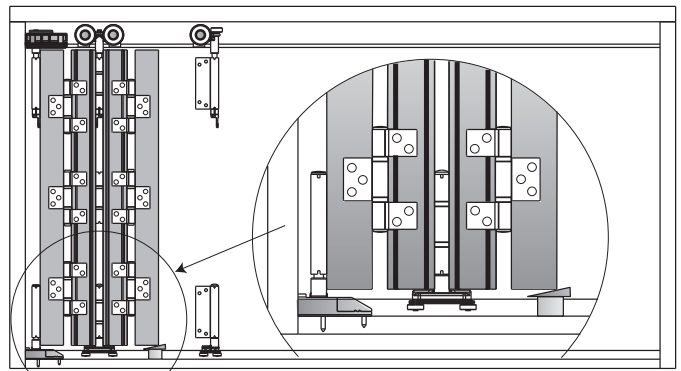

Final Adjustment

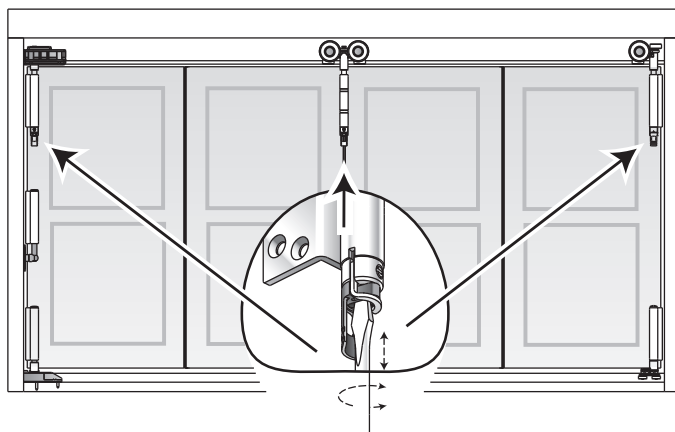

Remove Shipping Clip

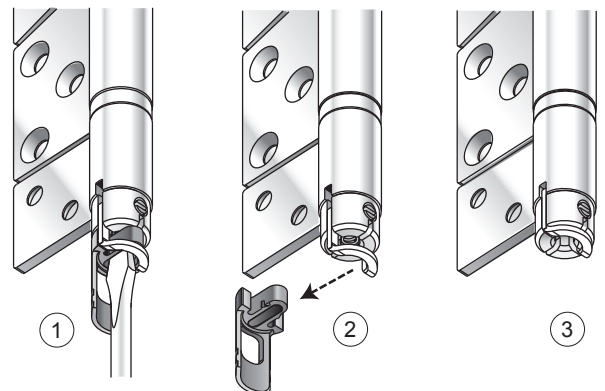

Using Surelock™ is simple:

1. Surelock™ is supplied with a plastic shipping clip installed to make initial adjustment very easy.
2. Insert a flathead screwdriver into the slot to rotate the pin.
3. When correct adjustment is reached and doors operate well, remove the shipping clip (it's seriously ugly to help you remember).
4. Surelock™ will automatically snap into place when the blade and slot are aligned.
5. To readjust at a later date, simply pull the blade down to disengage it from the slot and rotate the pin.

NO SCALE

Elevation & Overview

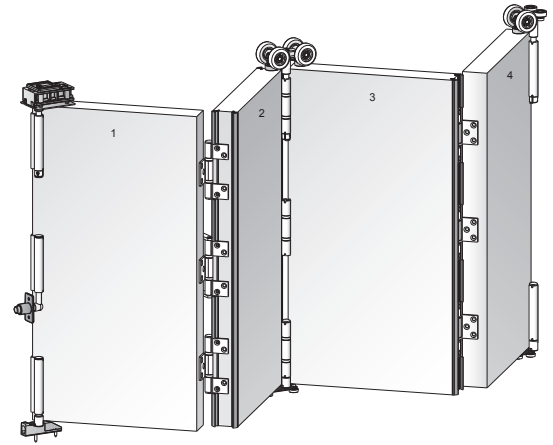
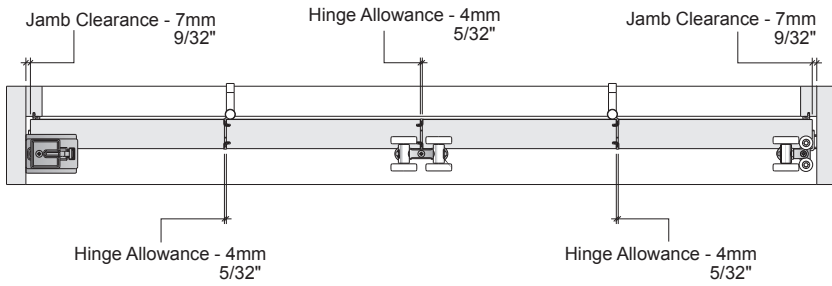

E3 Architectural Detail

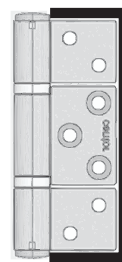
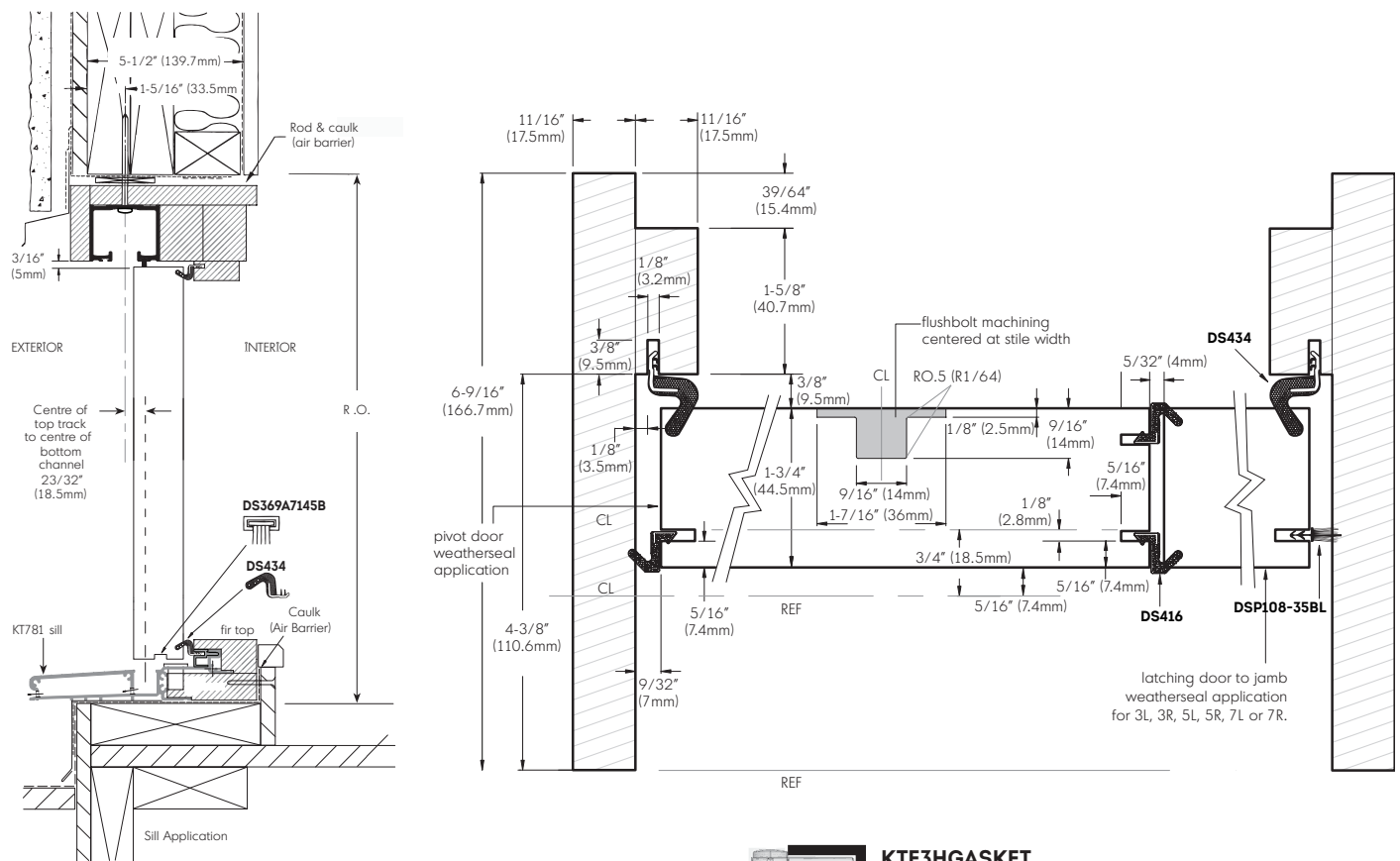

KTE3HGASKET
Adhesive back gasket for optimum sealing performance around all hinge flaps.

← Neoprene gasket, black

NO SCALE

E3™ SYSTEM Installation Instructions

Site Measuring

1. Check substrate of the rough opening (walls, floor and head structure) and make sure that all components are sound, suitable and ready to receive the door jambs, sill, top track / header and doors.

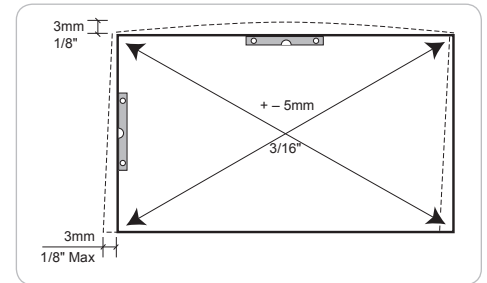

2. Determine the most appropriate type of fastener (i.e. screws, bolts etc) to be used for head, sill and jambs. Screws are supplied for top track installation into rough opening header.

3. Determine in and out position of the door frame. Line up the centerline of the head track with the header beam to which it will be fastened (not applicable when using E3 sill, jamb & header system). Note that fasteners must penetrate through solid material and that offset installation may cause roll and twist of the header beam. R.O. header must not deflect more than 2mm (1/16") when carrying the weight of the doors.

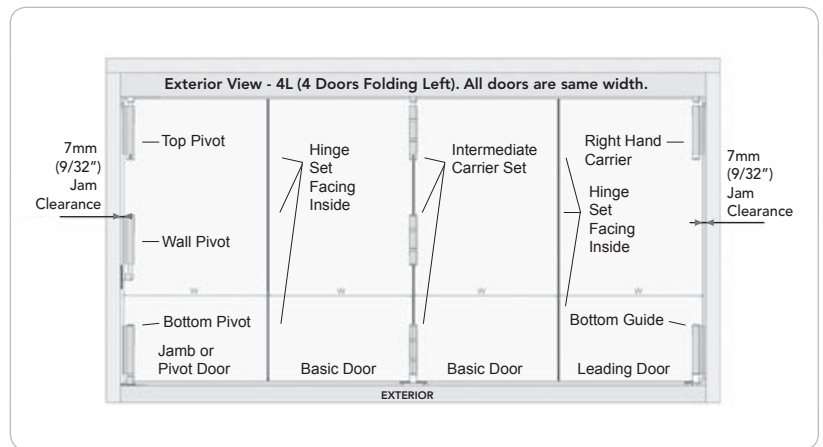

NOTE: Wherever conditions are unsatisfactory, do not proceed with installation.

4. Establish and measure clear, square-opening sizes. Straight edge and level tools should be used. Ensure that all measurements follow straight lines and apply to square corner conditions.

Door Framing (Applies To both the Bottom Floor U-Channel and E3 Sill System)

5. Construct the door frame to the measurements taken. Attach one gasket to each end of sill before attaching jamb.

6. Before fitting the track into the jamb head assembly, insert the Top Pivot Assembly into the track at each end, which has a pivot. The back of the pivot must be flush with the end of track and all other hardware.

7. Fit the extruded aluminum track to the door frame head assembly and secure with temporary alignment screws (#8 x 12.7 mm (1/2") placed at 1000 mm (39") on center.

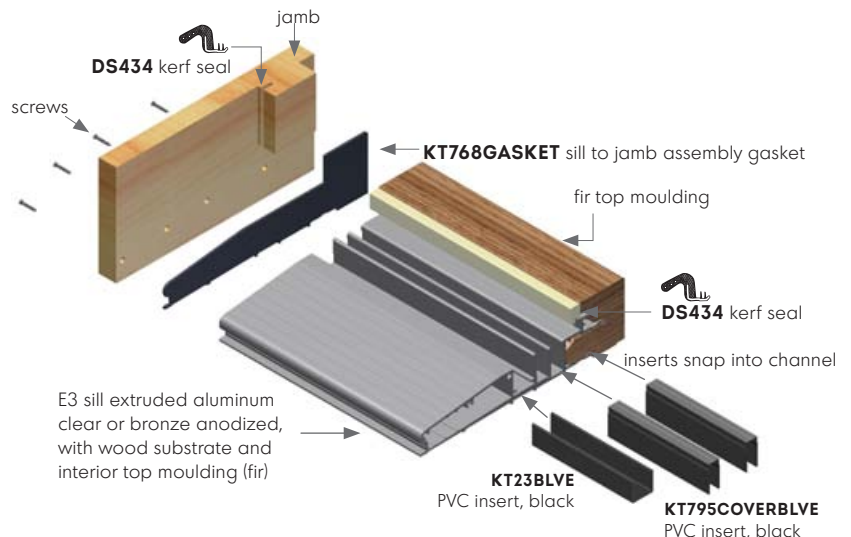

NO SCALE

8. Prepare the head of door frame to receive installation (structural) fasteners. Pre-drill clearance holes through the track and door frame head. The holes to be at drilled at 400 mm (16") on center maximum. In addition, using 76 mm (3") spacing, drill five (5) more holes for fasteners that are needed at the end(s) where the doors stack. Top track may be pre-drilled for you.

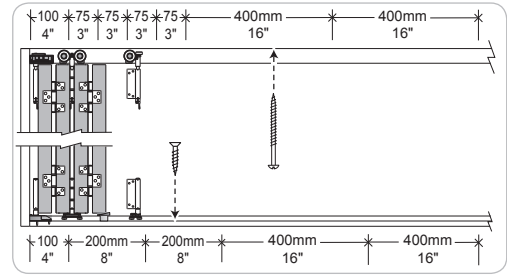

9. Structural (suspension), steel, round end, flat head fasteners should be at least #12 or 14 x 76 mm. (3" long) and penetrate by 38 mm (1 1/2") into the rough opening's structural header beam that carries the load of the door panels.

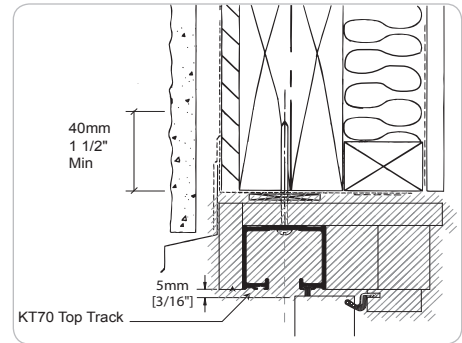

10. Unscrew the head fasteners and remove the extruded aluminum top track from door frame.

11. Clean inside of top track cavity and completely remove all metal shavings and other contamination. Failure to do so will embed debris into the wheels and track profile. Note that contamination of metal parts restricts the ease of operation of the doors.

12. Drill and countersink the bottom extruded aluminum track channel for #8 x 1/2" flat head stainless steel screws. Place holes at 400 mm (16") on center. (This does not apply for application of the E3 Self-Draining Sill). Fasten sill to floor through wood portion of sill only. Caulk under sill accordingly.

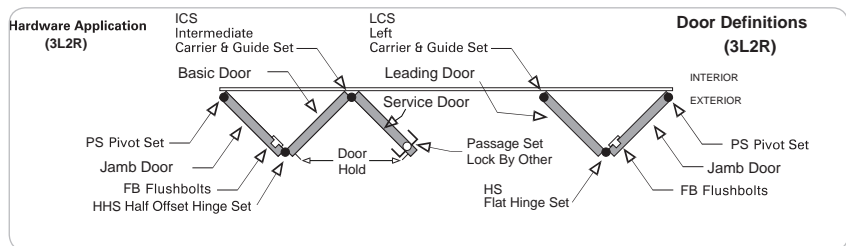

13. Drill clearance holes in the extruded aluminum sill channel for floor pivot fixings. Caulk under pivot and seal the hole.

14. Insert the extruded aluminum sill channel into the door frame sill and drill pilot holes into the door frame for the fasteners. Screw down firmly. (This does not apply for application of the E3 Self-Draining Sill).

15. Apply waterproofing sealant compound (i.e. silicone sealant) at the butt joint facing the jamb at the end of the sill track. Use sill end gasket when using E3 sill assembly.

16. Position and screw the floor pivot blocks using #8 x 3/4 flat head screws for wood door frame sill, or the #8 x 1/2" flat head screws for the E3 Self-Draining Sill.

17. Calculate panel widths using the door opening (internal) jamb-to-jamb dimension. **NOTE:** All door panels are the same width for E3 systems.

18. Panel heights are the vertical sill-to-head dimension less 15 mm (9/16"). This allows for top 5 mm (3/16") and bottom 10 mm (3/8") panel edge clearance.

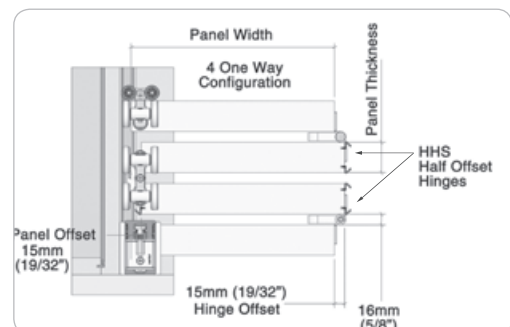

NO SCALE

19. Fabricate the panels to the required sizes.

20. Make kerf cuts (for weather seal gaskets) along the vertical edges of the panels as required. Position kerf cuts so the edge of the weather-seal gasket projects 1 mm (1/32") past the door face. Machine bottom of each door to hold the KT369 pile seals.

21. In correct orientation, make a stack of the panels for each side of the door opening. Lay the panels horizontally with 15 mm spacers between. Note carefully the top and bottom of each panel and align the two ends and all sides as they will be in the final, fully open position.

22. On door stiles, mark the locations of all hinges and flaps to be fitted. Note that all carrier hinges, carrier flaps and pivot flaps are to be mounted 15 mm (9/16") from the top of each panel and 15 mm (9/16") from the bottom of each panel. Hinge sets should be mounted far enough (2 1/2" - 60 mm) to clear the doorstops on the head and sill.

23. Mark positions for and route recesses for the Flushbolts. For quick installation, use the Eclipse router bit (KTE2DBFORB). Flushbolts are machined into every odd numbered panel. (i.e. 1st, 3rd, 5th & 7th panel from each side.)

24. Fit all hinges, floor guides, intermediate and end carriers to door stiles. For proper installation, all hinge and pivot flap screw holes should be pre-drilled. A standard, self-centering bit should be used.

25. Unscrew one side of relevant hinges / carriers from stiles at each intermediate carrier location and separate panels into appropriate pairs.

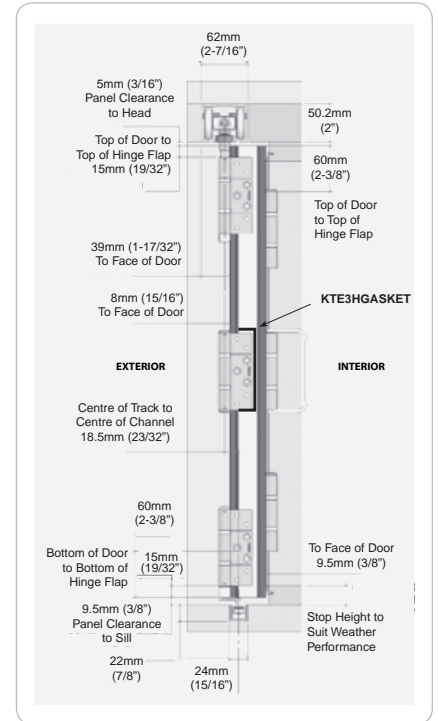
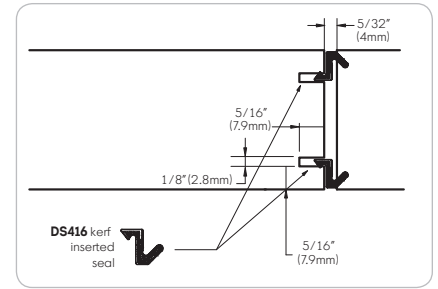

Door Frame Installation

26. Loose fit the door frame into the opening (and ensure it is in the correct position)

27. Position the door frame so that the head and sill are located in the desired position as indicated above. Shim under the sill to provide for vertical support for traffic loads, and lateral support to resist wind load.

28. At the jambs, install wedges or similar items and use screws to secure temporarily the door frame in the rough opening.

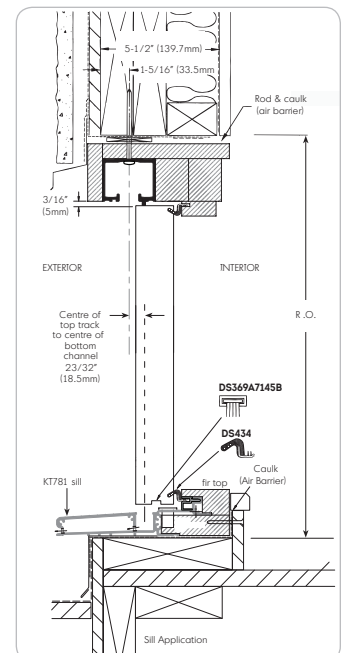

NO SCALE

29. Insert shims under the door frame sill and ensure it is straight, level and well supported. Make sure that the door frame sill is level or its middle part bows (concave) slightly down by no more than 2 mm. Avoid any upwards bow (convex) deformation.

30. At the top and bottom of door frame, shim tight both jambs to the rough opening, and make the jambs plumb.

31. Check that the center of the extruded aluminum head (top) track to centre of bottom channel is 18.5 mm (23/32"). Verify and ensure that the frame is not out of plane or twisted. Use the edge of the doorstop as the reference face.

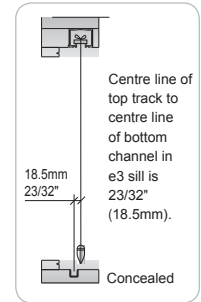

32. Finally, double-check the door frame squareness by verifying that the diagonals do not differ by more than 5 mm (13/64").

33. Use suitable fasteners and secure both the **top** and **bottom** of each door frame jamb at the shimmed locations.

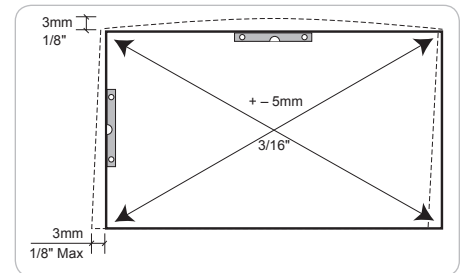

34. At suitable spacing (maximum 600 mm (24") o/c) insert additional shim-spacers behind the door frame jambs and apply appropriate anchoring fasteners. Make sure that the spacers are of appropriate thickness and that the door frame jambs are straight and plumb and not bowing in or out by more than 3 mm (1/8").

35. Fix the door frame sill to the rough opening / building structure. Apply fasteners at necessary spacing not exceeding 600 mm (24"). Fasten sill down to subfloor. Do not drill through aluminum profile of the E3 sill.

Top Track Fitting

36. Drill pilot screw holes into the structural head beam of rough opening. Note that steel and concrete structures require additional preparation.

37. Remove the extruded aluminum track from the door frame head and clean it thoroughly. Failure to do so damages the wheels and prevents easy operation. Note that inappropriate preparation and the resulting damage of the hardware will void warranty.

38. Lay the track in the opening to check that all parts are in the correct orientation and order. Insert the carriers and top pivot assemblies into the clean head track. Make sure carriers are facing the right way.

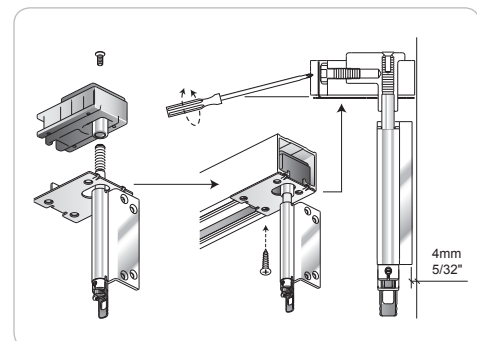

39. Fit the track into the door frame head and secure with the original alignment screws.

40. Secure the door frame head with the appropriate fasteners. Check that the door head assembly is straight, or has a slight bow upwards not exceeding 3 mm (1/8").

NO SCALE

41. Use flat head screws supplied and secure each Top Pivot Assembly into top track.

42. Once more thoroughly clean the extruded aluminum head track and remove any debris (i.e. chips stripped from screw heads etc). Check that the carriers move freely along the full length of the track.

43. Lubricate the track and the wheels with a small quantity of white petroleum jelly (Vaseline). This will improve smooth operation, and help to preserve the bearings and track.

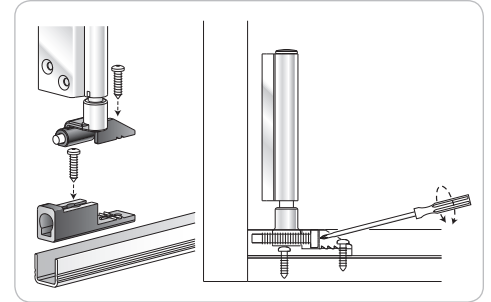

Door Panel Hanging Starting with Pivot Door(s)

44. Set the door panels in the open position (or 90 degrees to opening) and place them on supporting shims. The bottom edge of door panels should be level and at the sill height, or slightly above. At this point hinge flaps are not attached to door but hanging in opening.

45. Screw-secure top pivot hinge into the pre-drilled holes on door. Screw bottom hinge into door.

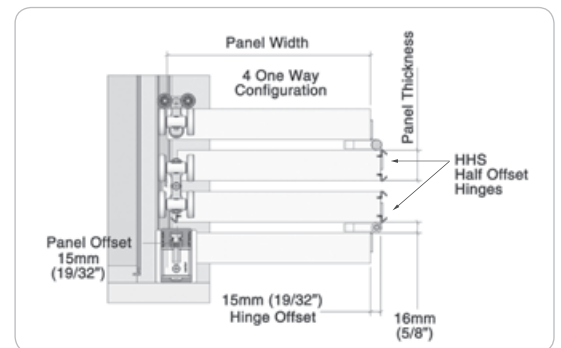

46. Close the door panel and check for a consistent gap (approximately 9/32" - 7mm) between the side jamb and the door panel. Adjust the gap by turning the top and bottom pivot adjustment screws.

47. Provide an even panel top gap of 5 mm (3/16") and an even bottom gap of 10 mm (3/8").

48. While dealing with any pivot or carrier vertical adjustment, always support the weight of the door panels with a flat / pry bar or similar tool.

49. On floor and head pivots, adjust horizontal screws so that the jamb panels are precisely plumb. Note that the door panels must be fully open to prevent damage to adjusting screws and to allow for horizontal adjustments.

50. Open door panels, adjust all the carriers vertically with a suitable screwdriver and set flush-straight the top edges of all panels.

51. Test-operate all door panels. Inspect the gaps at the end panels while the doors are closed. If the gaps are uneven, open the doors and adjust the horizontal screw on the top and bottom pivots.

NO SCALE

Final Adjustment

52. Fine-tune and adjust until the doors operate smoothly, and the gaps are even and acceptable.

53. Remove the carrier-shipping clip (“yellow”) from each carrier, and turn the carrier pin engaging the SureLock™ (see the illustration).

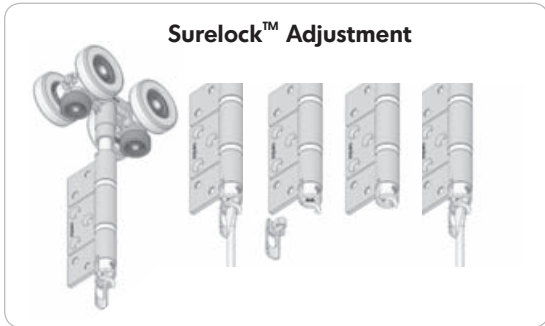

Surelock™ is the trademark for Centor’s carrier pin locking system (patents granted). Carrier pins at the top pivots, intermediate and end carriers support the full door weight and it is here that the height of the panels is adjusted. Surelock™ ensures that once the heights are set, they stay set.

Using Surelock™ is simple:

- Surelock™ is supplied with a plastic shipping clip installed to make initial adjustment very easy.
- Insert a flat bladed screwdriver into the slot to rotate the pin.
- When correct adjustment is reached and doors operate well, remove the shipping clip (it’s seriously ugly to help you remember).
- Surelock™ will automatically snap into place when the blade and slot are aligned.
- To readjust at a later date, simply pull the blade down to disengage it from the slot and rotate the pin.

54. Snap bottom pivot caps into place.

55. Fit Flushbolts to doors and fit drop bolt cups into sill. Make sure the gasket is fitted under the cup rim. The gasket has an adhesive back on both sides for sealing purposes. Caulk around rim and cup mounting holes before securing cup to sill with screws.

56. Fit Flushbolts to doors and fit drop bolt cups into sill. Make sure the gasket is fitted under the cup rim. The gasket has an adhesive back on both sides for sealing purposes. Caulk around rim and cup mounting holes before securing cup to sill with screws.



KT749
Flushbolt cup
used with floor
channel and
ADA sill

Maintenance

All products must be installed in accordance with accepted good trade practice (and in accordance with supplied instructions where applicable), and maintained in accordance with these procedures or else the warranty shall be void.

Automatic Closers & Operators

All Centor Products Pty Ltd. hardware systems are designed for manual operation. Poorly adjusted automatic operator closers can impart significant destructive forces to tracks, bearings and stops. Such hardware used in installations is expressly excluded from Centor Products Pty Ltd. warranty terms.

Hardware in buildings is subject to deterioration from everyday use, and also from environmental attack due to atmospheric and other conditions. Maintenance of hardware is even more important in severe environments such as coastal marine areas and some industrial areas. Even stainless steel products require maintenance to prevent deterioration in some environments. Centor Products Pty Ltd. requires the following minimum maintenance to be followed, otherwise the warranty shall be void :

Track & Bearings

Using a spatula or similar (not your finger), apply a small amount (typically a 1/4 teaspoon) of white petroleum jelly (Vaseline) or similar lubricant to the inner lip of each side of the track.

Ensure that the wheels pass through the lubricant and it is distributed evenly along the track. Put additional lubricant around bearings. Lubricant reduces wear, improves smoothness and

further protects against corrosion of track and bearings. Remove all surface contaminants by wiping all visible track surfaces with a damp cloth and a mild detergent, then wipe with a clean cloth. In severe environments, apply a thin film of a corrosion preventative such as CRC Marine 66®, Innox® or WD40®, by wiping with a soft cloth moistened with one of these products.

Stainless-steel bearings are manufactured from hardening-grade stainless-steel and although this material performs considerably better than plated steels, it is still susceptible to corrosion unless maintained as described above.

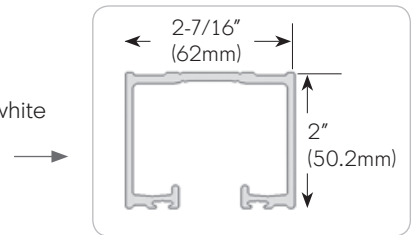

Hangers, Pivots & Brackets

A light spray application of a corrosion preventative such as CRC Marine 66®, Innox® or WD40®, followed by a light wipe with a dry cloth to remove excess, is recommended to all hangers, pivots and brackets. Exposed surfaces should first be wiped down with warm soapy water and a soft rag, and then rinsed clean before applying preventative.

Hinges

Wipe down the visible surfaces with warm soapy water on a soft rag and then rinse off by wiping with a clean damp rag. Application of a thin film of a light machine oil or one of the corrosion preventative sprays mentioned above will help to maintain the original lustre of the metal finish. Be careful not to get these compounds on the timberwork itself as they may cause staining.

Flushbolts

Spray application of a suitable lubricant such as CRC Marine 66®, Innox® or WD40® to the sliding pin inside the bolt and to the lock cylinder is recommended. A tube attached to the nozzle will help to concentrate the spray where you want it to go. There are access holes or slots on all flushbolt products so that this can be done without removing the locks from the doors.

Frequency

The procedures mentioned above need to be carried out as often as is necessary to prevent deterioration in the installed environment, however we recommend the following minimum frequency of application :

General environments: every 6 months

Marine and industrial environments: every 3 months

Regular maintenance is required to all hardware, even stainless steel, otherwise the manufacturer's warranty may be voided.

NO SCALE

Warranty

Eclipse Warranty

Eclipse Architectural® offers a 5 year warranty on its products. This warranty only applies to all products other than all hardware manufactured by Centor Products Pty Ltd. Defective goods will be replaced; however no claims for damage incurred or work done thereon will be allowed. The Eclipse program is a complete product offering. Component deletions and/or substitutions are strictly prohibited. Warranty is void if product has missing or substitute products.

Centor Warranty

Centor Products Pty Ltd. offers a 10 year limited warranty on its hardware and tracking products. This warranty only applies to hardware and tracking products manufactured by Centor and used on Eclipse Folding Door Systems.

Centor Products Pty Ltd. warrants its hardware and tracking products to be free from manufacturing defects for a period of 10 years from the date of purchase.

A manufacturing defect is defined as where the product or component sold is not of merchantable quality nor fit for its intended purpose. Where Centor Architectural products or components are installed or incorporated into another entity's or manufacturer's product, Centor Architectural will not be liable for any defect in that product.

What is not covered

Other than manufacturing defects, this warranty excludes all other defects in Centor Products Pty Ltd.'s products including defects caused or contributed in whole or in part by, or resulting from, any of the following :

- a) Abuse, misuse or neglect;
- b) Circumstances where the products are used for purposes other than the intended use;
- c) Natural disasters such as flooding, windstorms and lightning;
- d) Damage caused by the external environment in which the products are situated;
- e) Alterations to the products by any person unless authorized by Centor Products Pty Ltd.;
- f) Failure to follow the recommended installation and maintenance procedures.

Liability for consequential and other damages

Centor Products Pty Ltd. shall not be liable under this warranty under any circumstances for any other direct or any indirect, incidental or consequential damages of any kind. Centor Products Pty Ltd.'s liability in respect of products that it finds to have manufacturing defects is limited to repairing or replacing the defective products. The repair or replacement of the defective product will be to a standard that provides the same degree of serviceability or functionality that a product without defect would otherwise have.

Centor Products Pty Ltd. will not be liable in contract, tort or otherwise for costs, expenses, loss or damage to any person or property, including consequential losses or loss of profits, resulting directly or indirectly from any defect or breach of warranty.

This is the only warranty

This warranty is for carriers, hinges, pivots, guides and flushbolts only. This is the only warranty provided by Centor Products Pty Ltd. All other warranties, whether expressed or implied by any legislation, are hereby excluded to the extent permitted by such legislation.

New Generation E3 Top Track & E3 Channel Sill

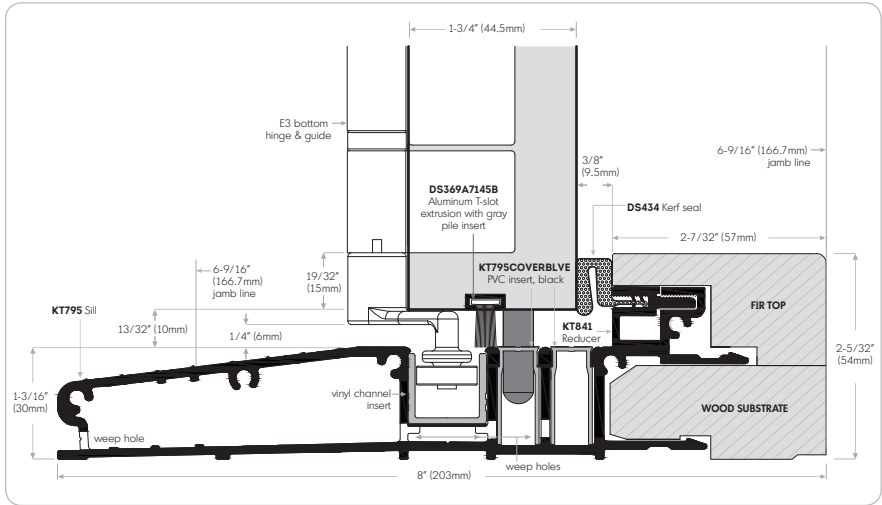

New E3 Sill For 2 X 4 Wall Thickness

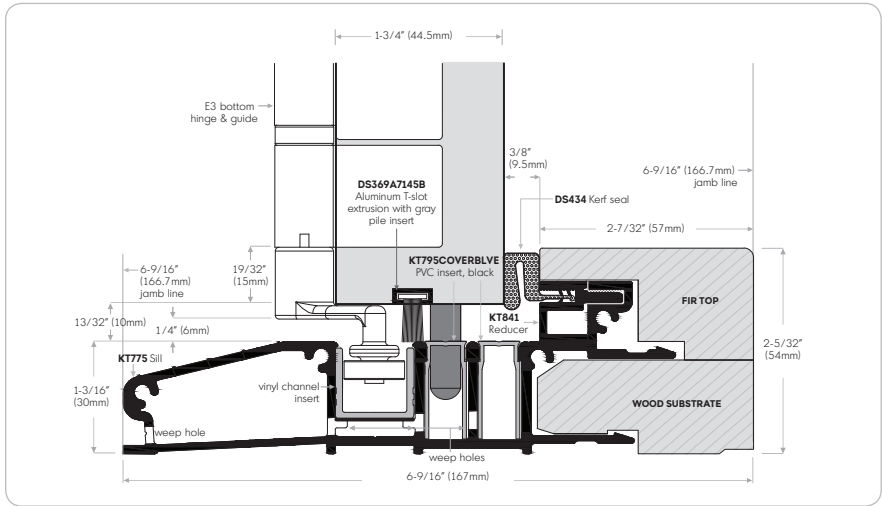
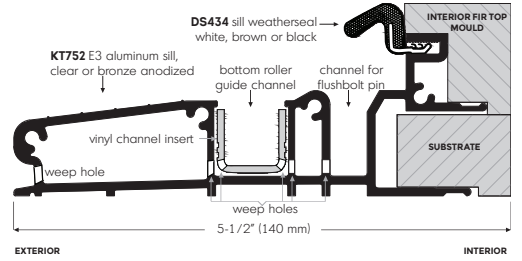

New Low Rise Aluminum Sill

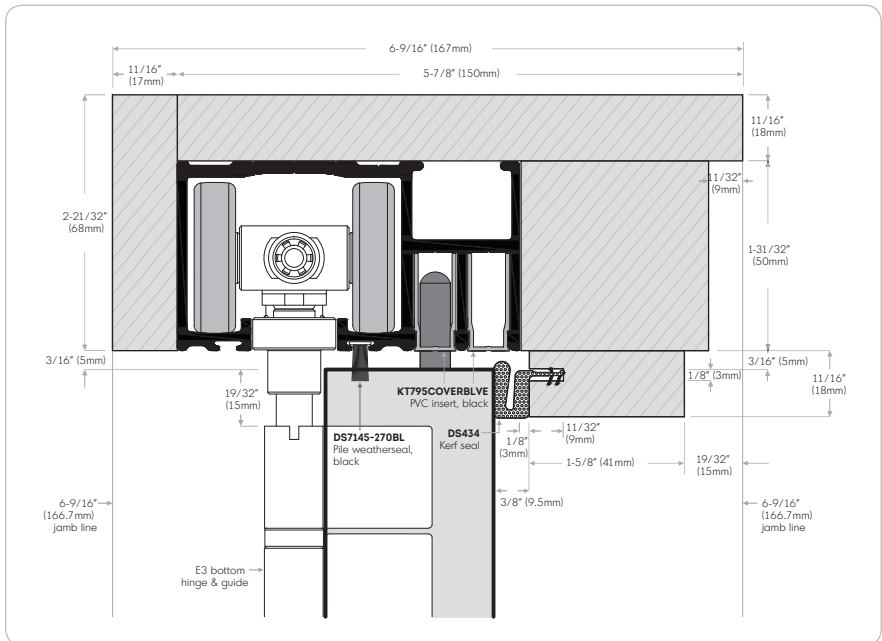
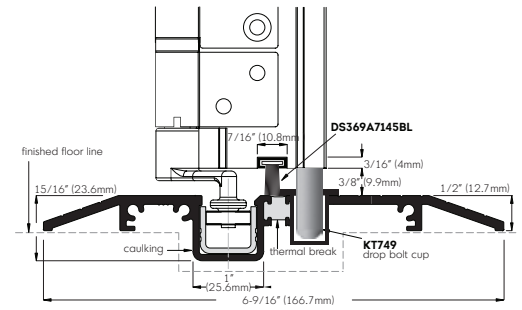

NO SCALE

E3 CLAD

Aluminum CLAD Systems for E3 Head & Jamb

brick mould

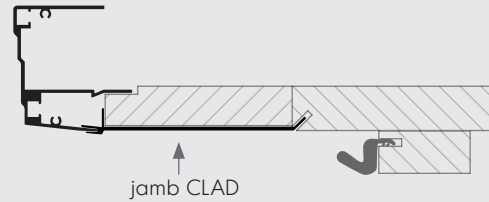
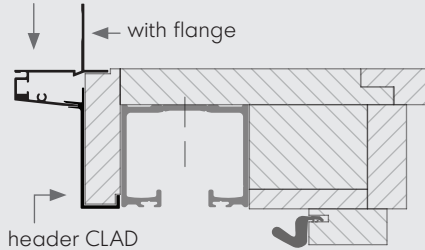

brick mould

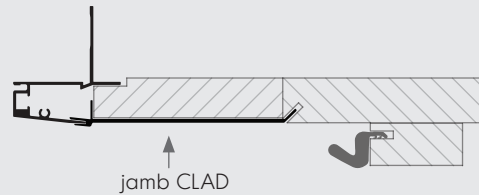
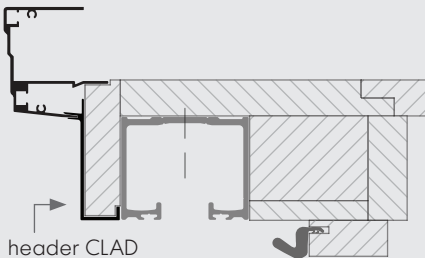

DS Group®

www.theDSgroup.com

Tomorrow's Innovative Solutions for Today's Doors & Windows

The DS Group Of Companies : Draftseal®, Kristrack®, Eclipse Architectural® & DSD Hardware

Head Office & Manufacturing Centre, Vancouver, Canada

7470 Buller Avenue, Burnaby, B.C. V5J 4S5 Canada

Phone: (604) 451-1080 • Fax: (604) 451-1140 • info@theDSgroup.com

Outside Vancouver, B.C., please use our toll free numbers: Phone: 1-888-520-9009 Fax: 1-800-567-2887

Branch Office & Manufacturing Centre, Toronto, Canada

Phone head office toll free 1-888-520-9009 for branch address

Branch Office & Distribution Centre, Los Angeles, California

Phone head office toll free 1-888-520-9009 for branch address

Eclipse Architectural® Corporate Showrooms

Vancouver & Toronto, Canada • Los Angeles, California, USA

THE DS GROUP IS THE BRAND IMAGE OF A.K. DRAFT SEAL LTD.