

Eclipse Architectural[®]

HARDWARE SYSTEMS FOR FOLDING DOORS

E2 SYSTEM FOR EXTERIOR FOLDING DOORS & WINDOWS

INSTALLATION MANUAL



E2 Installation Manual

Thank you for choosing the E2 Eclipse Architectural hardware system for exterior folding doors. The hardware, made with great care, if installed correctly will provide years of trouble-free operation. The following instructions provide guidelines for measuring and fitting the suspended folding doors complete with the Eclipse E2™ Hardware System.

E2 SYSTEM SPECIFICATIONS (IN A SINGLE DIRECTION):

max panel weight: 130 lbs (60 kg)

max panel width: 43" (1100mm)

max panel height: 118" (3000mm)

max number of panels: 8 each way

panel thickness when using E2 sill system: 1-3/4" (44.45 mm)

panel thickness when using floor channel: 1-3/8" (34.93mm), 1-3/4" (44.45mm) or 2-1/4" (57.15mm)

While this guide is as comprehensive as possible, it cannot address all eventualities, which may be encountered on site. Regardless of the quality of the hardware or construction of the panels, the most important criteria for a successful job are:

Level, flat rough floor

Square rough opening

Structurally sound and unyielding rough opening header

Clean door assembly tracks

NOTE: Eclipse Architectural is unable, and does not control, the actual site measuring and installation of the doors or hardware, and therefore does not assume any responsibility for the performance of the installed product.

The instructions below should be followed and adhered to. The provided below step-by-step instructions can assist any fabricator or installer. Installation is best done with more than one person.

NOTE TO ECLIPSE DOOR FABRICATOR:

Please attach this E2 Installation Manual to door before shipping to job site.

Site Measuring

1. Check substrate of the rough opening (walls, floor and head structure) and make sure that all components are sound, suitable and ready to receive the door jambs, sill, top track / header and doors.
2. Determine the most appropriate type of fastener (i.e. screws, bolts etc) to be used for head, sill and jambs. Screws are supplied for top track installation into rough opening header.
3. Determine in and out position of the door frame. Line up the centerline of the head track with the header beam to which it will be fastened (not applicable when using E2 sill, jamb & header system). Note that fasteners must penetrate through solid material and that offset installation may cause roll and twist of the header beam. R.O. header must not deflect more than 1/16" (2mm) when carrying the weight of the doors.
4. Note: Wherever conditions are unsatisfactory, do not proceed with installation.
5. Establish and measure clear, square-opening sizes. Straight edge and level tools should be used. Ensure that all measurements follow straight lines and apply to square corner conditions.

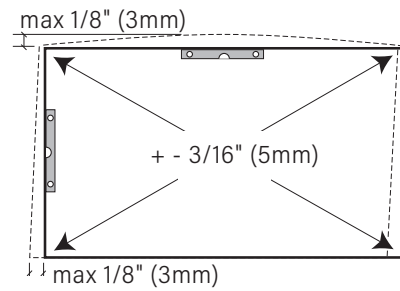

Optional floor channel application

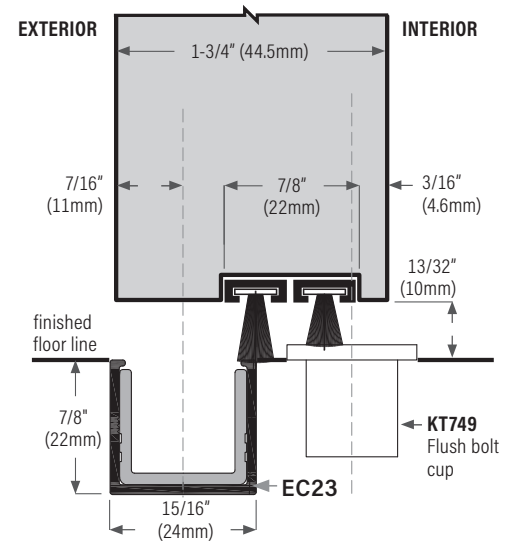

this application is recommended only for interior application, non-rainfall weather conditions or undercover, well protected doors. Door calc will not calculate R.O. when using EC23 floor channel.

Door Framing

(Applies To both the Bottom Floor U-Channel and E2 Sill System)

6. Construct the door frame to the measurements taken. Attach one gasket to each end of sill before attaching jamb.
7. Before fitting the track into the jamb head assembly, insert the Top Pivot Assembly into the track at each end, which has a pivot. The back of the pivot must be flush with the end of track.
8. Fit the extruded aluminum track to the door frame head assembly and secure with temporary alignment screws (#8 x 1/2" (12.7mm) placed at 39" (1000mm) on center.
9. Prepare the head of door frame to receive installation (structural) fasteners. Pre-drill clearance holes through the track and door frame head. The holes to be drilled at 16" (400mm) on center maximum. In addition, using 3" (76mm) spacing, drill five (5) more holes for fasteners that are needed at the end(s) where the doors stack. Top track may be predrilled for you.

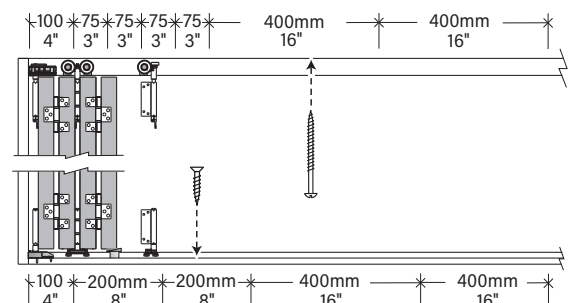
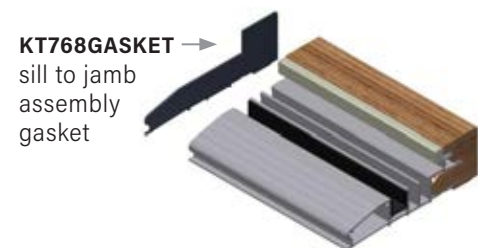

10. Structural (suspension), steel, flat head fasteners should be at least #12 or 14 x 76mm. (3" long) and penetrate by 1-1/2" (38mm) into the rough opening's structural header beam that carries the load of the door panels.

11. Unscrew the head fasteners and remove the extruded aluminum top track from door frame.

12. Clean inside of top track cavity and completely remove all metal shavings and other contamination. Failure to do so will embed debris into the wheels and track profile. Note that contamination of metal parts restricts the ease of operation of the doors.

13. Drill and countersink the bottom extruded aluminum track channel for #8 x 3/4" flat head stainless steel screws. Place holes at 16" (400mm) on center. (This does not apply for application of the E2 Self-Draining Sill). Fasten sill to floor through wood portion of sill only. Caulk under sill accordingly.

14. Drill clearance holes in the extruded aluminum sill channel for floor pivot fixings. Caulk under pivot and seal the hole.

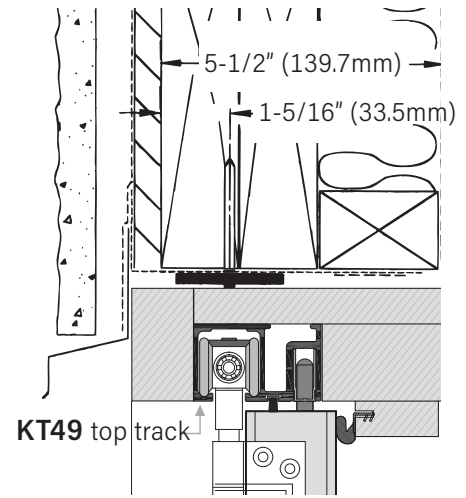

3L2R Hardware Application

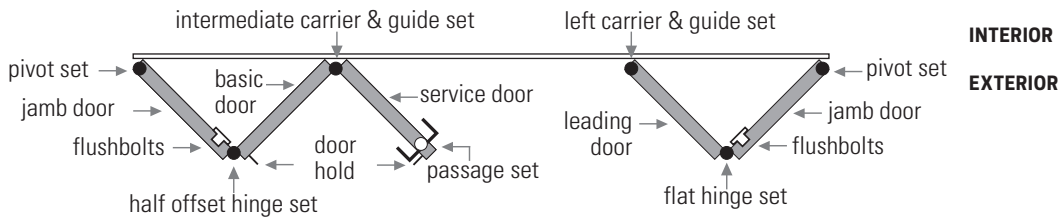

15. Insert the extruded aluminum sill channel into the door frame sill and drill pilot holes into the door frame for the fasteners. Screw down firmly. (This does not apply for application of the E2 Self-Draining Sill).

16. Apply waterproofing sealant compound (i.e. silicone sealant) at the butt joint facing the jamb at the end of the sill track. Use sill end gasket when using E2 sill assembly.

17. Position and screw the floor pivot blocks using #8 x 3/4 flat head screws for wood door frame sill, or the #8 x 1/2" flat head screws for the E2 Self-Draining Sill.

18. Calculate panel widths using the door opening (internal) jamb-to-jamb dimension. **Note: All door panels are the same width for E2 systems.**

19. Panel heights are the vertical sill-to-head dimension less 9/16" (15mm). This allows for top 3/16" (5mm) and bottom 3/8" (10mm) panel edge clearance.

20. Fabricate the panels to the required sizes.

21. Make kerf cuts (for weather seal gaskets) along the vertical edges of the panels as required. Position kerf cuts so the edge of the weather-seal gasket projects 1/32" (1mm) past the door face. Machine bottom of each door to hold the EC369 pile seals.

22. In correct orientation, make a stack of the panels for each side of the door opening. Lay the panels horizontally with 15mm spacers between. Note carefully the top and bottom of each panel and align the two ends and all sides as they will be in the final, fully open position.

23. On door stiles, mark the locations of all hinges and flaps to be fitted. Note that all carrier hinges, carrier flaps and pivot flaps are to be mounted 9/16" (15mm) from the top of each panel and 15 mm (9/16") from the bottom of each panel. Hinge sets should be mounted far enough (2-1/2" / 60mm) to clear the doorstops on the head and sill.

24. Mark positions for and route recesses for the Flushbolts. For quick installation, use the Eclipse router bit (KTE2DBFORB). Flushbolts are machined into every odd numbered panel. (i.e. 1st, 3rd, 5th & 7th panel from each side.)

25. Fit all hinges, floor guides, intermediate and end carriers to door stiles. For proper installation, all hinge and pivot flap screw holes should be pre-drilled. A standard, self-centering bit should be used.

26. Unscrew one side of relevant hinges / carriers from stiles at each intermediate carrier location and separate panels into appropriate pairs.

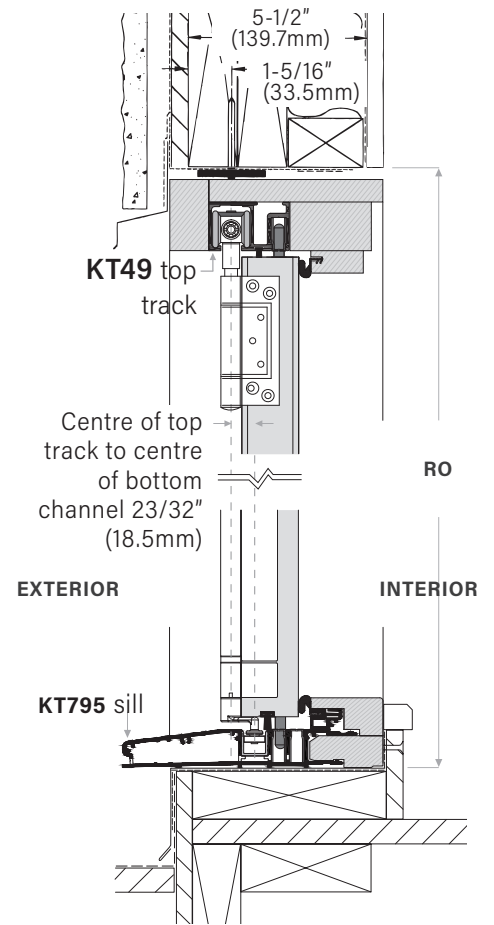

Door Frame Installation

27. Loose fit the door frame into the opening (and ensure it is in the correct position)

28. Position the door frame so that the head and sill are located in the desired position as indicated above. Shim under the sill to provide for vertical support for traffic loads, and lateral support to resist wind load.

29. At the jambs, install wedges or similar items and use screws to secure temporarily the door frame in the rough opening.

30. Insert shims under the door frame sill and ensure it is straight, level and well supported. Make sure that the door frame sill is level or its middle part bows (concave) slightly down by no more than 2 mm. Avoid any upwards bow (convex) deformation.

31. At the top and bottom of door frame, shim tight both jambs to the rough opening, and make the jambs plumb.

Hinge Set Placement

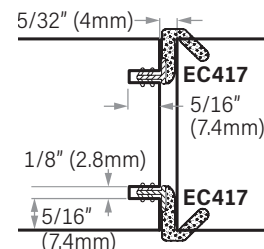
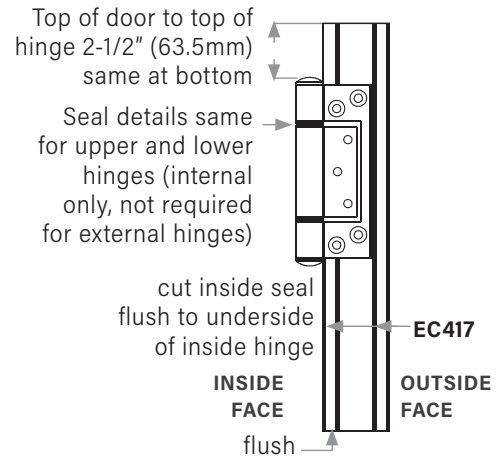

32. Check that the centre of top track to centre of bottom channel is 23/32" (18.5mm). Verify and ensure that the frame is not out of plane or twisted. Use the edge of the doorstop as the reference face.

33. Finally, double-check the door frame squareness by verifying that the diagonals do not differ by more than 13/64" (5mm).

34. Use suitable fasteners and secure both the **top** and **bottom** of each door frame jamb at the shimmed locations.

35. At suitable spacing (maximum 24" (600mm) o/c) insert additional shim-spacers behind the door frame jambs and apply appropriate anchoring fasteners. Make sure that the spacers are of appropriate thickness and that the door frame jambs are straight and plumb and not bowing in or out by more than 1/8" (3mm).

36. Fix the door frame sill to the rough opening / building structure. Apply fasteners at necessary spacing not exceeding 24" (600mm). Fasten sill down to subfloor. Do not drill through aluminum profile of the E2 sill.

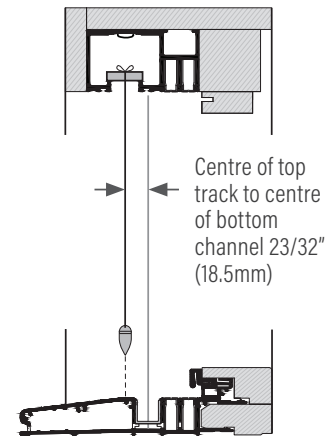

Top Track Fitting

37. Drill pilot screw holes into the structural head beam of rough opening. Note that steel and concrete structures require additional preparation.

38. Remove the extruded aluminum track from the door frame head and clean it thoroughly. Failure to do so damages the wheels and prevents easy operation. Note that inappropriate preparation and the resulting damage of the hardware will void warranty.

39. Lay the track in the opening to check that all parts are in the correct orientation and order. Insert the carriers and top pivot assemblies into the clean head track. Make sure carriers are facing the right way.

40. Fit the track into the door frame head and secure with the original alignment screws.

41. Secure the door frame head with the appropriate fasteners. Check that the door head assembly is straight, or has a slight bow upwards not exceeding 1/8" (3mm).

42. Use flat head screws supplied and secure each Top Pivot Assembly into top track.

43. Once more thoroughly clean the extruded aluminum head track and remove any debris (i.e. chips stripped from screw heads, etc). Check that the carriers move freely along the full length of the track.

44. Lubricate the track and the wheels with a small quantity of white petroleum jelly (Vaseline). This will improve smooth operation, and help to preserve the bearings and track.

45. Set the door panels in the open position (or 90 degrees to opening) and place them on supporting shims. The bottom edge of door panels should be level and at the sill height, or slightly above. At this point hinge flaps are not attached to door but hanging in opening.

Door Panel Hanging Starting with Pivot Door(s)

46. Screw-secure top pivot hinge into the predrilled holes on door. Screw bottom hinge into door.

47. Close the door panel and check for a consistent gap (approximately 9/32" / 7mm) between the side jamb and the door panel. Adjust the gap by turning the top and bottom pivot adjustment screws.

- 48. Provide an even panel top gap of 3/16" (5mm) and an even bottom gap of 3/8" (10mm).
- 49. While dealing with any pivot or carrier vertical adjustment, always support the weight of the door panels with a flat / pry bar or similar tool.
- 50. On floor and head pivots, adjust horizontal screws so that the jamb panels are precisely plumb. Note that the door panels must be fully open to prevent damage to adjusting screws and to allow for horizontal adjustments.
- 51. Open door panels, adjust all the carriers vertically with a suitable screwdriver and set flush-straight the top edges of all panels.
- 52. Test-operate all door panels. Inspect the gaps at the end panels while the doors are closed. If the gaps are uneven, open the doors and adjust the horizontal screw on the top and bottom pivots.

Final Adjustment

- 53. Fine-tune and adjust until the doors operate smoothly, and the gaps are even and acceptable.
- 54. Remove the carrier-shipping clip ("yellow") from each carrier, and turn the carrier pin engaging the SureLock™ (see the illustration).
- 55. Snap bottom pivot caps into place.
- 56. Fit Flushbolts to doors and fit drop bolt cups into sill. Make sure the gasket is fitted under the cup rim. The gasket has an adhesive back on both sides for sealing purposes. Caulk around rim and cup mounting holes before securing cup to sill with screws.

Surelock 5 Upgrade

The new Surelock 5 technology ensures folding doors running on E2 and E3 hardware can be adjusted simply with an Allen key. Offering seven upgrades from the original version, the new Surelock 5:

- Adjustment is self-evident with 8mm (5/16") Allen key added into the end of the pin.
- Removes the yellow shipping clip at the bottom of the pin – it can't be left in place after adjustment is finalized at installation.
- Use of the Allen key provides more torque, so the panel no longer needs to be 'unweighted' during adjustment.
- Eliminates the locking wafer which had possibility of shifting off-center and scratching the panel during adjustment.
- Allows for one-handed adjustment with the Allen key.
- Allows you to use an extended Allen key to adjust the door from ground level – a ladder or stool is no longer required.
- Looks great thanks to the simplified design of the pin.



1

The E3 hardware now accommodates:

Max. panel weight:
250lbs (115kg)

Max. panel height:
144" (3600mm)

Max. panel width:
48" (1200mm)



2



3

Maintenance

All products must be installed in accordance with accepted good trade practice (and in accordance with supplied instructions where applicable), and maintained in accordance with these procedures or else the warranty shall be void.

Automatic closers and operators - All Centor Products Pty Ltd. hardware systems are designed for manual operation. Poorly adjusted automatic operator closers can impart significant destructive forces to tracks, bearings and stops. Such hardware used in installations is expressly excluded from Centor Products Pty Ltd. warranty terms.

Hardware in buildings is subject to deterioration from everyday use, and also from environmental attack due to atmospheric and other conditions. Maintenance of hardware is even more important in severe environments such as coastal marine areas and some industrial areas. Even stainless steel products require maintenance to prevent deterioration in some environments. Centor Products Pty Ltd. requires the following minimum maintenance to be followed, otherwise the warranty shall be void:

Track and bearings - Using a spatula or similar object (not your finger), apply a small amount (typically a 1/4 teaspoon) of white petroleum jelly (Vaseline) or similar lubricant to the inner lip of each side of the track. Ensure that the wheels pass through the lubricant and it is distributed evenly along the track. Put additional lubricant around bearings. Lubricant reduces wear, improves smoothness and further protects against corrosion of track and bearings.

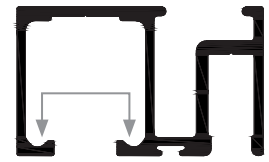

Remove all surface contaminants by wiping all visible track surfaces with a damp cloth and a mild detergent, then wipe with a clean cloth. In severe environments, apply a thin film of a corrosion preventative such as CRC Marine 66°, Innox® or WD40°, by wiping with a soft cloth moistened with one of these products.

Stainless-steel bearings are manufactured from hardening-grade stainless-steel and although this material performs considerably better than plated steels, it is still susceptible to corrosion unless maintained as described above.

Hangers, pivots and brackets - A light spray application of a corrosion preventative such as CRC Marine 66°, Innox® or WD40°, followed by a light wipe with a dry cloth to remove excess, is recommended to all hangers, pivots and brackets. Exposed surfaces should first be wiped down with warm soapy water and a soft rag, and then rinsed clean before applying preventative.

Hinges - Wipe down the visible surfaces with warm soapy water on a soft rag and then rinse off by wiping with a clean damp rag. Application of a thin film of a light machine oil or one of the corrosion preventative sprays mentioned above will help to maintain the original lustre of the metal finish. Be careful not to get these compounds on the timberwork itself as they may cause staining.

Flushbolts - Spray application of a suitable lubricant such as CRC Marine 66°, Innox® or WD40° to the sliding pin inside the bolt and to the lock cylinder is recommended. A tube attached to the nozzle will help to concentrate the spray where you want it to go. There are access holes or slots on all dropbolt products so that this can be done without removing the locks from the doors.

Frequency - The procedures mentioned above need to be carried out as often as is necessary to prevent deterioration in the installed environment, however we recommend the following minimum frequency of application:

General environments: Every 6 months

Marine and industrial environments: Every 3 months

Regular maintenance is required to all hardware, even stainless steel, otherwise the manufacturer's warranty may be voided

Limited Warranty

ECLIPSE ARCHITECTURAL® WARRANTY

Eclipse Architectural® offers a limited 5 year warranty on its products. This warranty only applies to all products other than all hardware manufactured by Centor Products Pty Ltd. Defective goods will be replaced; however no claims for damage incurred or work done thereon will be allowed. The Eclipse program is a complete product offering. Component deletions and/or substitutions are strictly prohibited. Warranty is void if product has missing or substitute products. Eclipse Architectural Products Ltd. reserves the right to inspect and test products to determine the validity of any claim made under this warranty.

CENTOR LIMITED WARRANTY

What the Warranty Covers

Centor North America Inc warrants the products to be free from manufacturing defects for a period of 10 years from the date of purchase. A manufacturing defect is defined as where the product or component sold is not of merchantable quality nor fit for its intended purpose. Where Centor North America Inc products or components are installed or incorporated into another entity's or manufacturer's product, Centor North America Inc will not be liable for any defect in that product.

What is Not Covered

Other than manufacturing defects, this warranty excludes all other defects in Centor North America Inc products including defects caused or contributed in whole or in part by, or resulting from, any of the following:

1. Abuse, misuse or neglect;
2. Circumstances where the products are used for purposes other than the intended use;
3. Natural disasters such as flooding, windstorms and lightning;
4. Damage caused by the external environment in which the products are situated
5. Alterations to the products by any person unless authorized by Centor North America Inc
6. Failure to follow the recommended installation and maintenance procedures

Liability for Consequential and Other Damages

Centor North America Inc shall not be liable under this warranty under any circumstances for any other direct or any indirect, incidental or consequential damages of any kind.

Centor North America Inc liability in respect of products that it finds to have manufacturing defects is limited to repairing or replacing the defective products. The repair or replacement of the defective product will be to a standard that provides the same degree of serviceability or functionality that a product without defect would otherwise have.

Centor North America Inc will not be liable in contract, tort or otherwise for costs, expenses, loss or damage to any person or property, including consequential losses or loss of profits, resulting directly or indirectly from any defect or breach of warranty.

This is the Only Warranty

This is the only warranty provided by Centor North America Inc. All other warranties, whether expressed or implied by any legislation, are hereby excluded to the extent permitted by such legislation.

Flushbolts For Outswing Folding Doors: DBOT Series

Max wind load: 450kg (990lb) force
Min door thickness: 1-3/4" (44.5mm)
Throw length: 1" (25mm)

Finishes:

Bronze powder coat on aluminum to match pvd bronze finish on E3 hinges.
 Brushed metallic on aluminum to match stainless steel finish on E3 hinges.

* Bright gold (TG) finish on aluminum to match pvd brass finish on E3 hinges.

* **Bright gold (TG) finish is custom order, call for manufacturing time.**

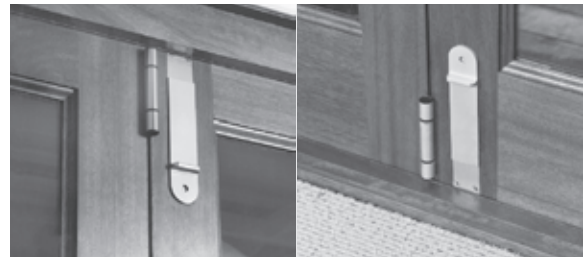

The flush-mounted flushbolts, rounded style and 1" (25mm) throw are designed for use with sliding and folding doors. This flushbolt will resist high winds and is rated to resist a 250kg load in Western Red Cedar and 450kg in Amoora. The bolts are easily installed with a dedicated router bit and are available in three finishes.

Architectural Detail

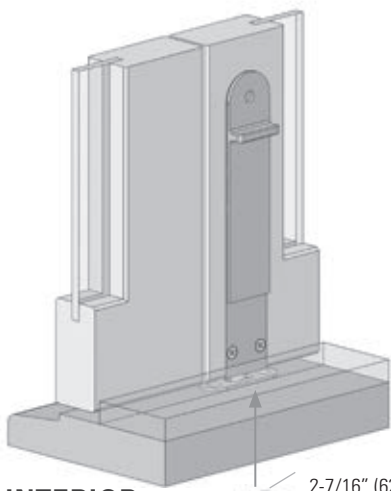

INTERIOR

7/8" (22mm)
 2-7/16" (62mm)
 13/16" (20.6mm)

KT749 Flushbolt cup used with floor channel and ADA sill

Flushbolt Assembly

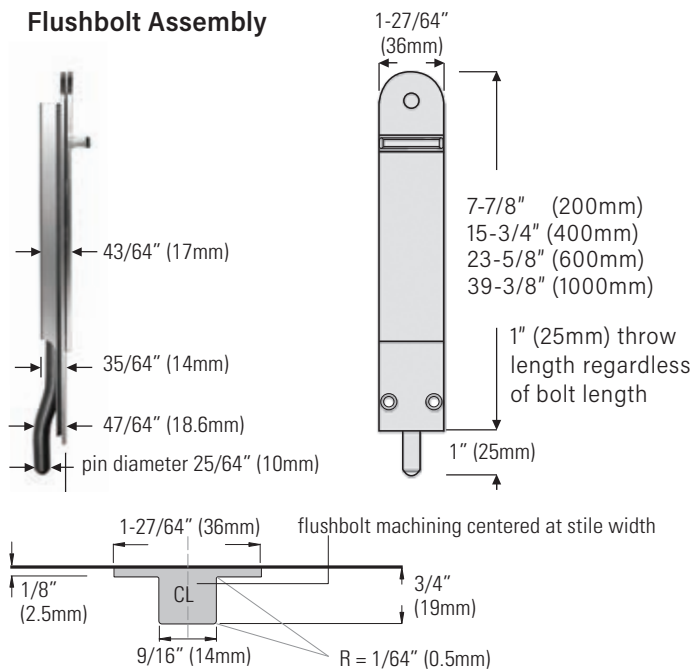

Actual machining for flushbolts (face plate)

1-27/64" x 7-7/8" (36mm x 200mm) 1-27/64" x 23-5/8" (36mm x 600mm)
 1-27/64" x 15-3/4" (36mm x 400mm) 1-27/64" x 39-3/8" (36mm x 1000mm)

SELECT FINISH

bronze powder coat finish on aluminum

PRODUCT NUMBER

KTDBOT200NRQ
KTDBOT400NRQ
KTDBOT600NRQ
KTDBOT1000NRQ

DESCRIPTION

8" (200mm) 1" throw, round end
 16" (400mm) 1" throw, round end
 24" (600mm) 1" throw, round end
 39" (1000mm) 1" throw, round end

brushed metallic finish on aluminum to match stainless steel

KTDBOT200NRX
KTDBOT400NRX
KTDBOT600NRX
KTDBOT1000NRX

8" (200mm) 1" throw, round end
 16" (400mm) 1" throw, round end
 24" (600mm) 1" throw, round end
 39" (1000mm) 1" throw, round end

bright gold finish on aluminum

* **KTDBOT200NRTG**
 * **KTDBOT400NRTG**
 * **KTDBOT600NRTG**

8" (200mm) 1" throw, round end
 16" (400mm) 1" throw, round end
 24" (600mm) 1" throw, round end



Flushbolt cup used with floor channel and ADA sill
KT749BRONZE bronze powder coat
KT749DCH Satin chrome

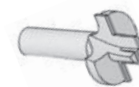

KTE2DBFORB Router bit for flushbolts (dedicated router bits are available)



Strike plate for header
KTDBSPQ bronze powder coat
KTDBSPS Satin chrome

*Bright gold (TG) finish is custom order, call for manufacturing time.

PLEASE NOTE: Flushbolt housing & slide bar are manufactured from aluminum components

Flushbolts For Outswing Folding Doors: DBSY Series

Max wind load: 450kg (990lb) force
Min door thickness: 1-3/4" (44.5mm)
Bolt lengths: 8", 16", 24", 39" (200mm, 400mm, 600mm, 1000mm)

Finishes:

Bright gold to match pvd brass hardware
 bronze powder coat on aluminum to match the pvd bronze hardware &
 brushed metallic to match stainless steel hardware



Symphony™

The flush-mounted flushbolts, rounded style and 1" (25mm) throw are designed for use with sliding and folding doors. Symphony™ will resist high winds and is rated to resist a 250kg load in Western Red Cedar and 450kg in Amoora. The bolts are easily installed with a dedicated router bit and are available in three finishes.

Architectural Detail

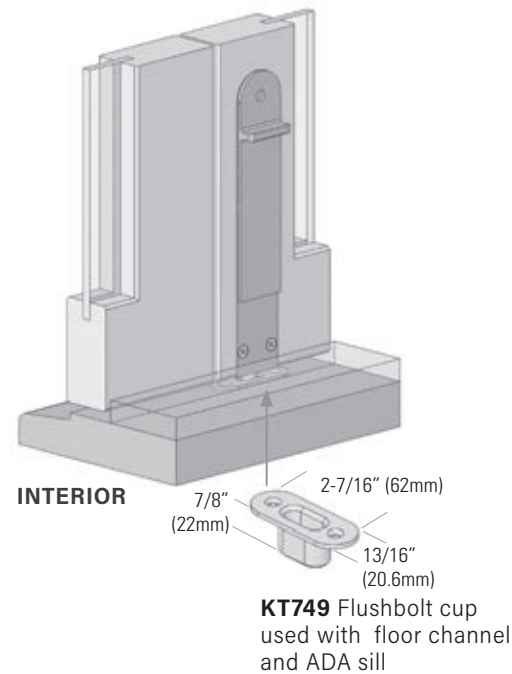

Flushbolt Assembly (Machining Spec)

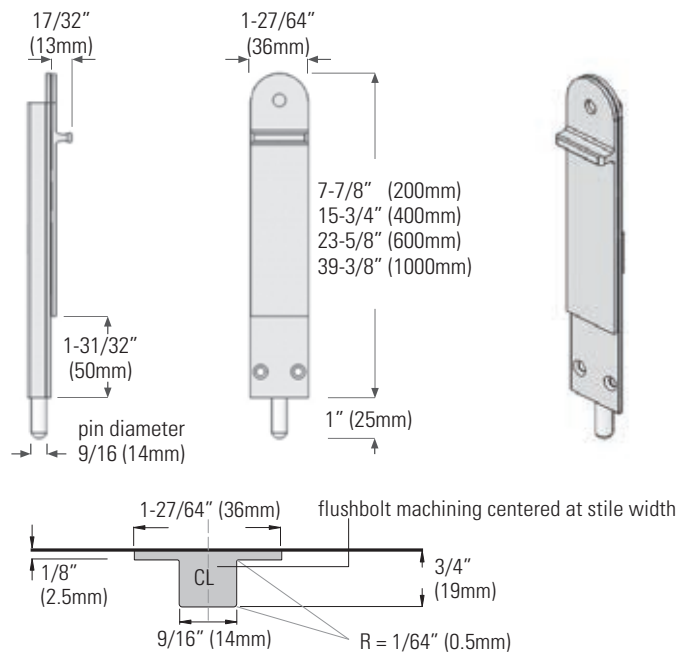

Actual machining for flushbolts (face plate)

1-27/64" x 7-7/8" (36mm x 200mm) 1-27/64" x 23-5/8" (36mm x 600mm)
 1-27/64" x 15-3/4" (36mm x 400mm) 1-27/64" x 39-3/8" (36mm x 1000mm)



Flushbolt cup used with floor channel and ADA sill
KT749BRONZE bronze powder coat
KT749DCH Satin chrome

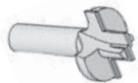

KTE2DBFORB Router bit for flushbolts (dedicated router bits are available)

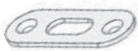

Strike plate for header
KTDBSPQ bronze powder coat
KTDBSPS Satin chrome

SELECT FINISH

powder coat finish
 bronze over
 aluminum

brushed metallic finish
 over aluminum to
 match stainless steel

bright gold finish
 over aluminum

PRODUCT NUMBER

- KTDBSY200NRQ**
- KTDBSY400NRQ**
- KTDBSY600NRQ**
- KTDBSY1000NRQ**
- KTDBSY200NRX**
- KTDBSY400NRX**
- KTDBSY600NRX**
- KTDBSY1000NRX**
- * **KTDBSY200NRTG**
- * **KTDBSY400NRTG**
- * **KTDBSY600NRTG**

DESCRIPTION

- 8" (200mm) 1" throw, round end
- 16" (400mm) 1" throw, round end
- 24" (600mm) 1" throw, round end
- 39" (1000mm) 1" throw, round end
- 8" (200mm) 1" throw, round end
- 16" (400mm) 1" throw, round end
- 24" (600mm) 1" throw, round end
- 39" (1000mm) 1" throw, round end
- 8" (200mm), 1" throw, round end
- 16" (400mm) 1" throw, round end
- 24" (600mm) 1" throw, round end

PLEASE NOTE: Flushbolt housing & slide bar are manufactured from aluminum components

*Bright gold (TG) finish is custom order, call for manufacturing time.

centor®

CENTOR BI-FOLDING DOORS
SOME PRACTICAL CONSIDERATIONS

Document Version: 2.0

Original File Location: G:\Products\7 Product Marketing Information\Practical Considerations for Bifolds V2.0.doc

TABLE OF CONTENTS

I. WEATHER STRIP GAP PINCHED	3
II. OVER CAMMING	4
III. NUMBER OF PANELS	5
IV. DOOR CONFIGURATIONS AND LOCKING SETS	6
V. NARROW STILES	7
VI. ACCESS PANEL DRAGS ON THE FLOOR OR DOORSILL	8

I. WEATHER STRIP GAP PINCHED

1. Description of issue:

When opening or closing a set of bi-fold doors there has to be a sufficient weather strip gap to prevent the panel hitting the internal stop face and tearing the internal stop seal.

2. Why this happens:

This occurs because the hinges on all pivot sets and end carriers make the door panel arc slightly towards the internal stop as it is being opened.

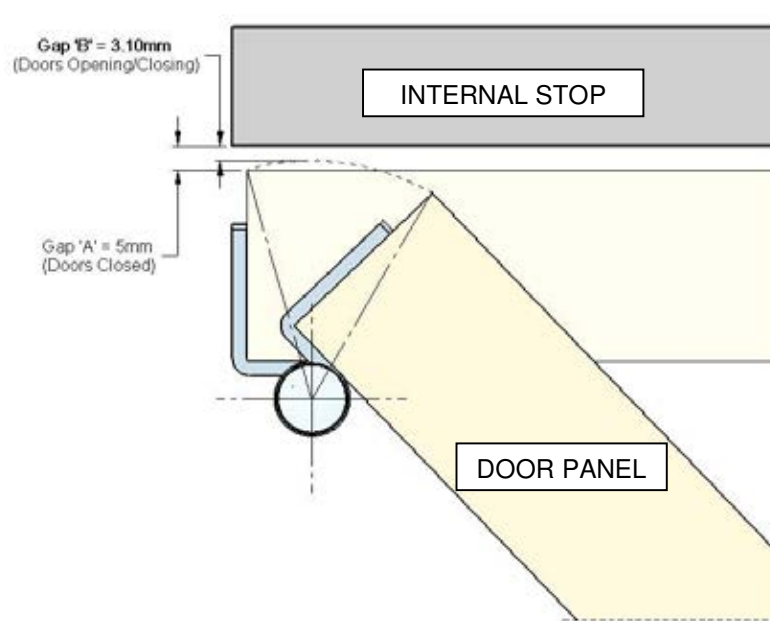

Pictured Above:

When opening a 40mm thick door panel a 5mm gap (Gap 'A') will be reduced by 1.9mm to 3.1mm (Gap 'B'). If the weather strip gap was smaller than 5mm it would leave insufficient room for the internal stop seal to compress.

3. How to avoid it:

Centor recommends that a minimum gap of 5mm is used for the weather strip gap on bi-folding doors.

II. OVER CAMMING

1. Description of issue:

When opening or closing a set of bi-fold doors, it is normal for a camming action to occur with the panels that, at a critical point, can cause resistance between them (Example below).

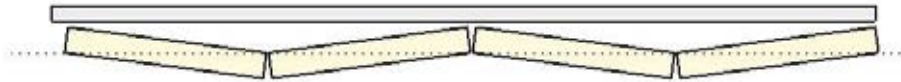

2. Why this happens:

Panels will cam across due to the arc that they pivot around and travel through.

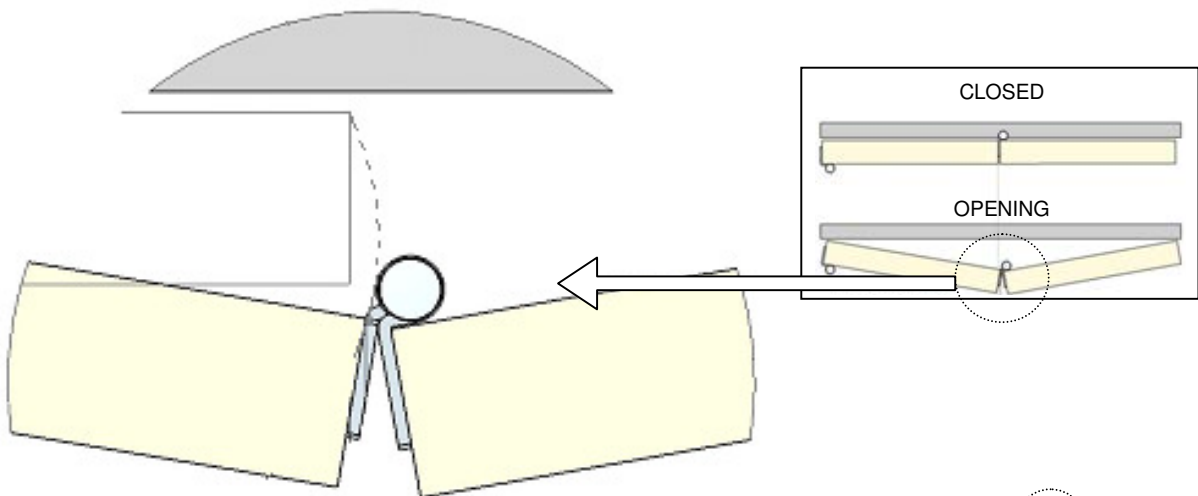

3. How to avoid it:

For even panel sets (e.g. 2L, 4R, 2L2R) you will always get some 'over-camming', however, you can reduce it by following these steps.

1. Unbolt the dropbolts on the first panel pair
2. Open the first pair of panels partly
3. Unbolt and partly open the remaining pairs
4. Now open them all together

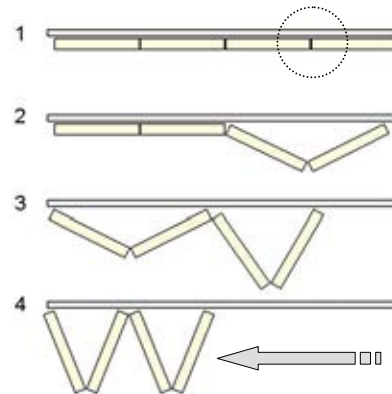

For odd panel sets (3L1R, 5R) you will avoid this completely by:

1. Always unlock and open the access panel first
2. Unlock the remaining dropbolts
3. Open all panels fully

The more panels a system has, the worse the over camming action will be, particularly if all dropbolts are unlocked before opening any panels.

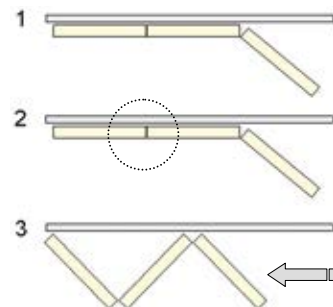

III. NUMBER OF PANELS

1. Description of Issue:

Centor hardware can work satisfactorily with an unlimited amount of door panels, provided the track and head is appropriately fastened and can support the weight of all panels whilst in the open position. However, the more panels there are in a system, the more cumbersome the doors can be to operate.

2. Why this happens:

There are a number of dimensional variations to consider with using an increasing numbers of panels. The most significant of these are:

1. The variation that can occur in door stile widths caused by:
 - Thermal expansion and contraction (Particularly PVC and aluminium)
 - Moisture content expansion and contraction changes in wood
 - Manufacturing tolerances of profiles
2. The variations that can occur in the length of top and bottom rails caused by:
 - Cutting tolerances in door panel fabrication
 - Thermal expansion and contraction (Particularly PVC and aluminium)

For a single door panel variation of 1mm (1/32") in the stiles and rails may seem insignificant, but over 8 panels this variation could have a considerable impact.

3. How to avoid it:

As a practical limit Centor recommends a maximum of 8 panels each way.

IV. DOOR CONFIGURATIONS AND LOCKING SETS

1. Description of Issue:

Passage locks are unsuitable for use in even panel configurations (e.g. 2L, 2L2R, 4R).

2. Why this happens:

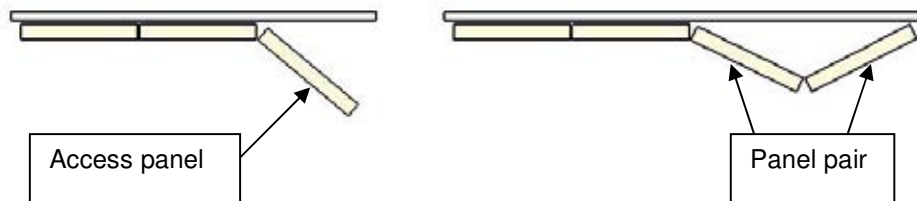

With bi-fold doors internal dropbolts lock off panels in pairs. However, in odd configurations there will always be a single panel that has to be locked off by itself. Only on a single panel can a passage lock be fitted, making it usable as an access panel. This will allow someone to open the access panel from both the inside and outside, unlike the panel pairs which can only be opened from the inside.

3. How to avoid it:

If external access is important then you will have to use odd panel configurations (e.g. 5L, 4L1R, 3R).

V. NARROW STILES

1. Description of Issue:

With all stiles it is important to know that the dropbolt positioning can interfere with hinge screws.

2. Why this happens:

The example below shows where the interference can occur between a dropbolt and hinge screws. This often happens with dropbolts centered on narrow stiles, particularly the ones used for windows.

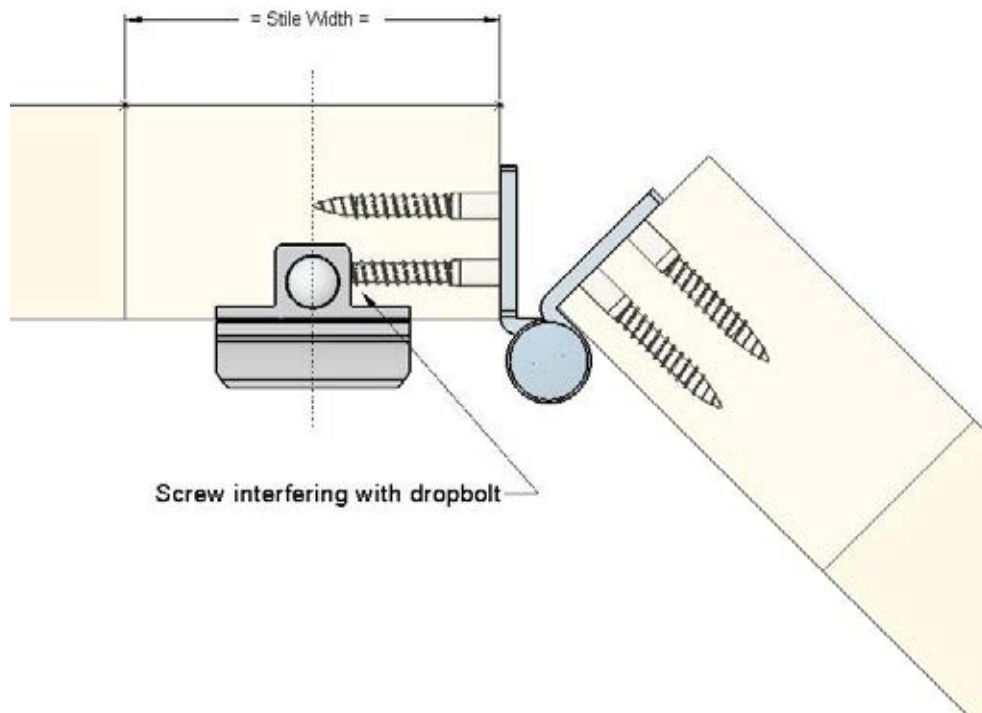

3. How to avoid it:

You can avoid this by changing the position of the dropbolts to be off centre of the stile (if it allows for this) or you can increase the stile widths. We do not recommend shortening the screws.

VI. ACCESS PANEL DRAGS ON THE FLOOR OR DOORSILL

1. Description of Issue:

Any door set with an odd number of panels greater than one coming from either side (3, 5, 7) is susceptible to the end of the lead or access panel (usually the one with the door handle attached) dropping and dragging on the ground as the door set is operated. This is most often experienced when

- either opening the doors by pushing the paired doors open without first folding the active leaf back onto the next panel, or
- closing the doors by swinging the active panel away from the stack and dragging the doors along the track

2. Why this happens:

Door panels are not very stiff in torsion – regardless of their construction type – wood, aluminium, PVC, even steel doors. They are basically a flat sheet.

When the bifold door pairs are opened and the lead door panel is not parallel to the next one (attached to the intermediate carrier), the cantilevered end panel pulls at the next panel, tending to twist it – just like a piano accordion opening up.

3. How to avoid it:

If the active leaf is secured parallel (or almost parallel) to the adjacent panel, then there is no twisting force applied to the door stack and the end panel will not drop. So, if the doors are opened in the correct sequence, then no door dropping will be experienced. Centor supplies a range of magnetic door holdbacks which will help with securing of the end panel.

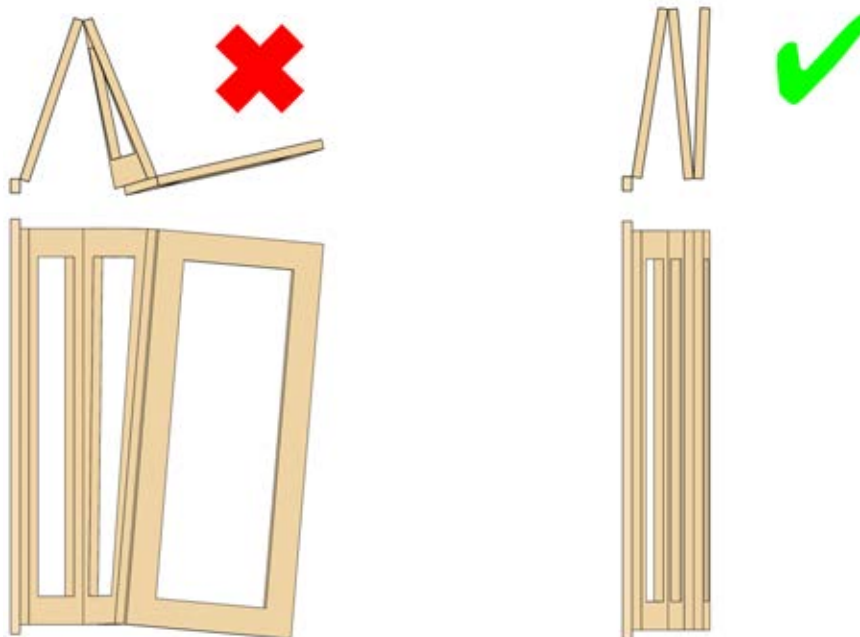

Eclipse Architectural[®]

HARDWARE SYSTEMS FOR FOLDING DOORS



Head Office - Vancouver, B.C. Canada

Unit 109 - 8288 North Fraser Way, Burnaby, B.C. V3N 0E9 Canada

www.eclipsearchitectural.com | info@eclipsearchitectural.com | Ph: (604) 901-6044 | Fax: (604) 901-6220

Branch Offices & Distribution Centres

Toronto, Ontario, Canada & Los Angeles, California, USA

Eclipse Architectural Showrooms

Toronto, Ontario, Canada & Los Angeles, California, USA