

# TANGENT FOLDING DELUXE 290

E A C H D O O R W E I G H T M A X 3 5 k g

## APPLICATION

- ▶ For residential and commercial folding partitions where weatherproofing to the head and sill of the opening may be required.
- ▶ All visible Tangent Folding Deluxe fittings are buffed to a satin finish and lacquered.
- ▶ To accommodate different building designs door leaves can fold to one or both sides of the opening and can be stacked behind a reveal if required.
- ▶ To cover any width of opening, any number of folding units can be used.
- ▶ Where doors are fitted externally, a canopy is recommended.

## DOOR SPECIFICATION

290

For individual leaves:	
Max Leaf Height	2400mm
Max Leaf Weight	35 kg
Max Leaf Width	900mm
Door Thickness	35-50mm

Folding units of up to eight leaves can be hinged to post or free-floating. A swinging access door can be included within a unit hinged to post incorporating an odd number of leaves. Alternatively, an access door can be independently hinged to post.

Floating units should always consist of an even number of leaves in units of four, six or eight.

Clearance between leaves to be 2mm minimum.

Door leaves should be constructed to provide secure fixing for hanger, hinges and guides and can either be flush, panelled or glazed.

## GEAR SPECIFICATION

<b>Track:</b>	290 (2mm thickness)
<b>Material:</b>	galvanised steel
<b>Standard Lengths:</b>	1800mm, 2000mm, 2500mm, 3000mm, 4000mm and 6000mm

<b>Brackets:-</b>		
face fixing	1A/290	aluminium alloy pressure die casting
soffit fixing	3A/290	aluminium alloy pressure die casting
Brackets for special applications are available (see overleaf).		
Fix at 900mm centres (maximum).		
Fix additional bracket where folding units stack.		

<b>Hangers:-</b>	
Intermediate hangers:	62K/P
End hanger:	63K/P
Aluminium hinge parts are buffed to a satin finish and lacquered.	
Hangers are fitted with steel wheels on sintered bush bearings.	
Vertical adjustment is simple and positive.	

<b>Guides:-</b>	
Intermediate guide:	67/94P
End guide:	68/94P
Aluminium hinge parts are buffed to a satin finish and lacquered.	

<b>Hinges:-</b>	403/3	butt hinge
	403/2	butt hinge

Fit three hinges high.

All steel parts to hangers and guides are electro-zinc plated.

<b>Channel:</b>	94X	aluminium
	94	brass

Standard lengths of aluminium channel correspond with standard track lengths, standard lengths of brass channel are 1500mm and 3000mm. Pre-drilled and countersunk for wood or lugging into concrete.

**Accessories:** Flush Pulls, Flush Bolts and Locks.

## EXTERNAL FOLDING DOORS TOP HUNG TIMBER OR METAL DOORS

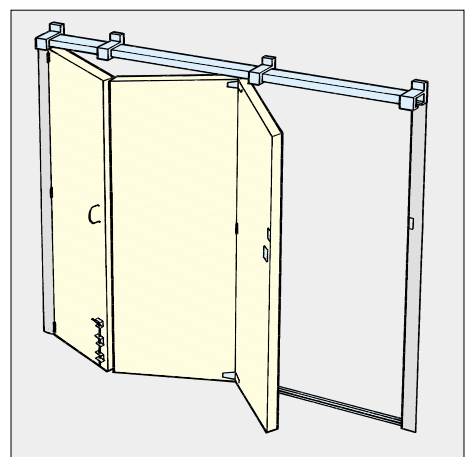
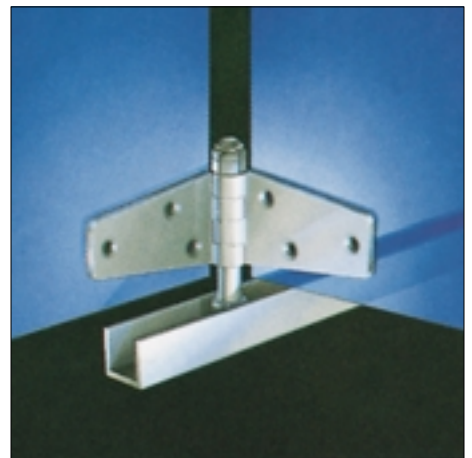

Standard Application

# TANGENT FOLDING DELUXE 290

