

# COLLEGE CENTERFOLD

# 140

E A C H D O O R W E I G H T M A X 1 4 0 k g

## APPLICATION

- ▶ Suitable for centre folding partitions in commercial or public buildings where weight has to be taken at floor level.
- ▶ Leaves are supported centrally under the lintel and can fold to one or both sides of the opening.
- ▶ College high quality bottom roller gear and fittings are ideally suited to high class joinery installations and all visible parts are finished in polished chrome and satin anodised aluminium.
- ▶ To cover any width of opening, any number of folding units can be used.

## DOOR SPECIFICATION

For individual doors:

Max Leaf Height	5500mm
Max Leaf Weight	140kg
Max Leaf Width	1000mm
Leaf Thickness	54mm

Folding units of up to seven full leaves and one half leaf can be hinged to post.

Floating units consist of five or seven full leaves.

Access doors should be either a separate swing door or a wicket door in one of the folding leaves.

All full leaves should be of an equal width. Instruction on leaf width calculation for full and half leaf are provided with the Expert Service and Joinery Instruction 2528.

Clearance between leaves to be 2mm minimum.

Door leaves should be constructed to provide secure fixing for bottom rollers, hinges and top guide rollers and can be either flush, panelled or glazed. Minimum 200mm bottom rails are recommended.

Refer to drawing 2769 for operating instructions.

## GEAR SPECIFICATION

<b>Top Guide Channel</b>	900 galvanised Steel with safety lips	
Standard lengths:	2000mm, 2500 mm and 3000mm	

<b>Top Guide Brackets:</b>		
soffit fixing	3/900	pressed steel zinc plated
Fix at every 600mm centres (maximum).		
Fit additional brackets where folding units stack.		

<b>Top Guide Rollers:</b>	901/919HD
Top guide rollers are fitted with adjustable nylon rollers.	
Vertical adjustment is simple and positive.	

<b>Bottom Rollers:</b>	909H	chrome finish
Bottom rollers supported on thrust bearings.		

<b>Hinges:</b>	403/3	butt hinge
On leaves up to 3000mm high fit 3 hinges, above 3000mm fit 4 hinges.		

<b>Rail:</b>	917
Standard lengths 1500mm and 3000mm	
Pre-drilled and countersunk for wood or lugging into concrete.	

<b>Accessories</b>	Flush Pulls, Flush Bolts and Locks.
--------------------	-------------------------------------

## INTERNAL FOLDING DOORS HINGED TO POST OR FLOATING BOTTOM ROLLER TIMBER DOORS

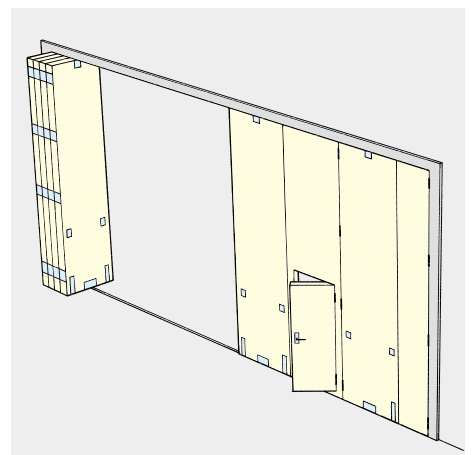
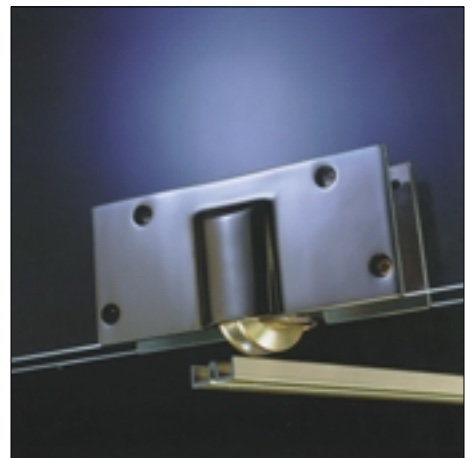
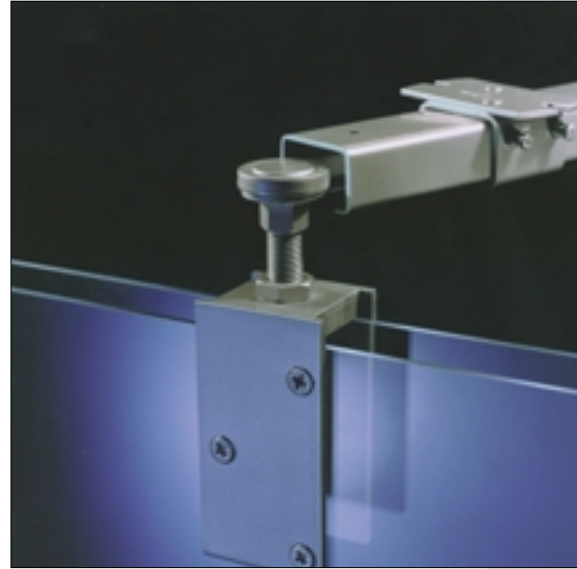

Standard Application

# COLLEGE CENTREFOLD 140

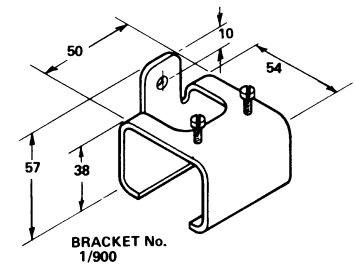
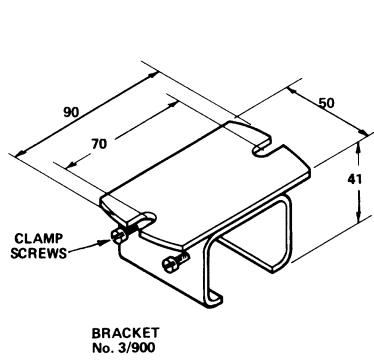
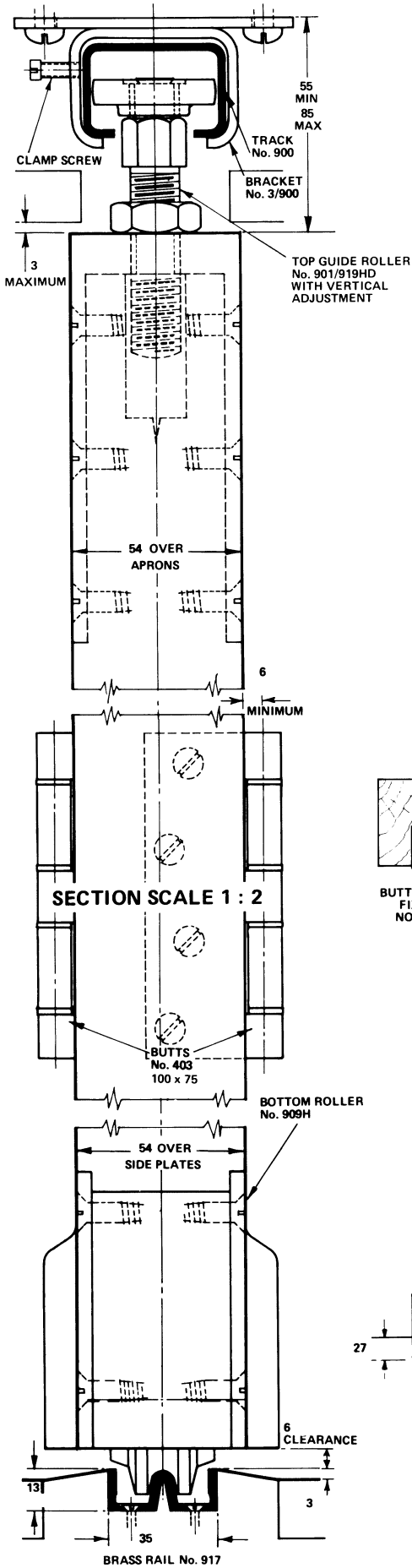

## COLLEGE CENTRE FOLD 140

PLEASE REFER TO JOINERY AND INSTALLATION DETAIL PRIOR TO CUTTING DOOR LEAVES.

MAXIMUM RECOMMENDED LEAF WIDTH IS 1000mm.

CLEARANCE BETWEEN LEAVES SHOULD NOT BE LESS THAN 2mm.

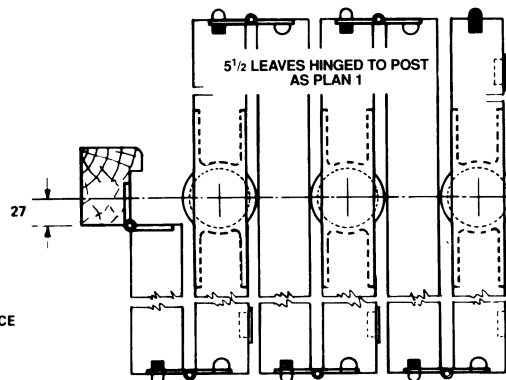
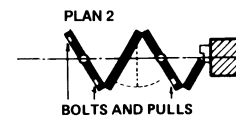
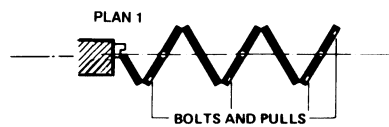
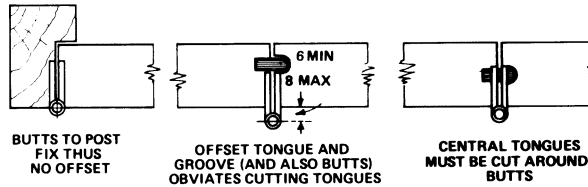

TONGUE AND GROOVE JOINTS WITH HARDWOOD TONGUES ARE RECOMMENDED

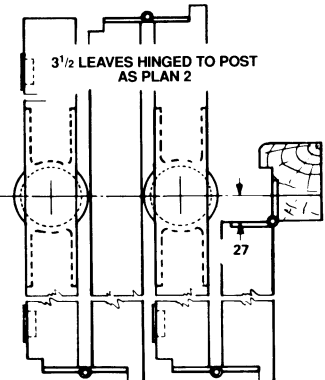

REBATED JOINTS IF REBATING IS PREFERRED IT MUST BE TO LAYOUT ABOVE