

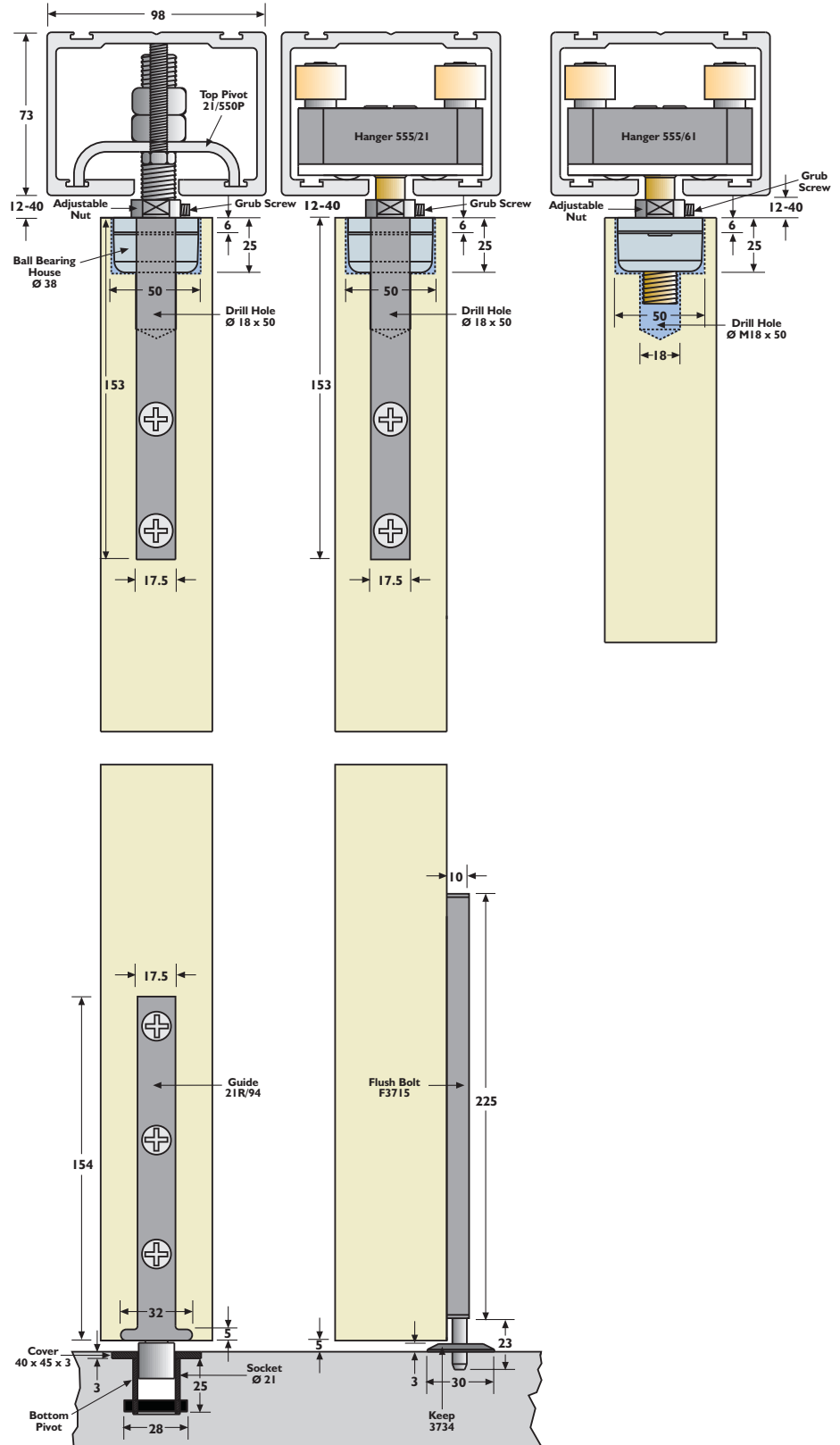

FLEXIROL 90° MULTIDIRECTIONAL SYSTEM FOR TIMBER AND ALUMINIUM DOORS



CAPACITY

Max. leaf weight:	100kg (2 hangers per leaf) 50kg (1 hanger per leaf)
Max. door height:	6000mm
Max. door width:	6000mm
Door thickness:	50mm-100mm
Max. swing door width:	1200mm

APPLICATIONS

Lightweight partitions for internal and external applications requiring 90° movement.

DOOR TYPES

Commercial timber and aluminium doors.

TECHNICAL INFORMATION

Track: 550 (extruded aluminium)

Intersects: 'T' junction TW/550
Cross-junction KW/550

Elbows: 90° elbow H90/550

Brackets: Face fix 1A/550
Soffit fix 3S/550

Hangers: Angle plate fixing 555/21
Concealed fixing 555/61

Pivots: Pivot set 21/550P

Accessories: Track stop HH3/301
Flush pull 400
Flush bolts 333/454
Narrow flush bolt and keep F3715 & F3734
Door closers

Floor spring closer 7410
Transom closer 5600
(complete with 400mm of 550 track)
Swing/slide floor spring 7305

90° Configurations

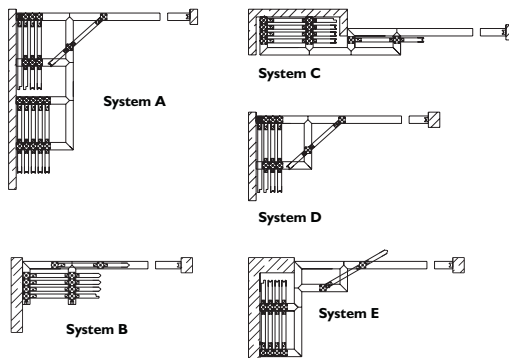

Door Rebates

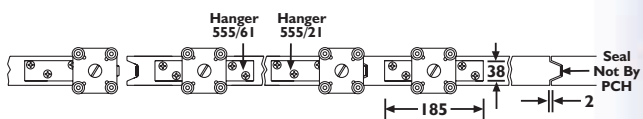

Example Rebated Doors

