

FLEXIROL 90° MULTIDIRECTIONAL SYSTEM FOR GLASS DOORS

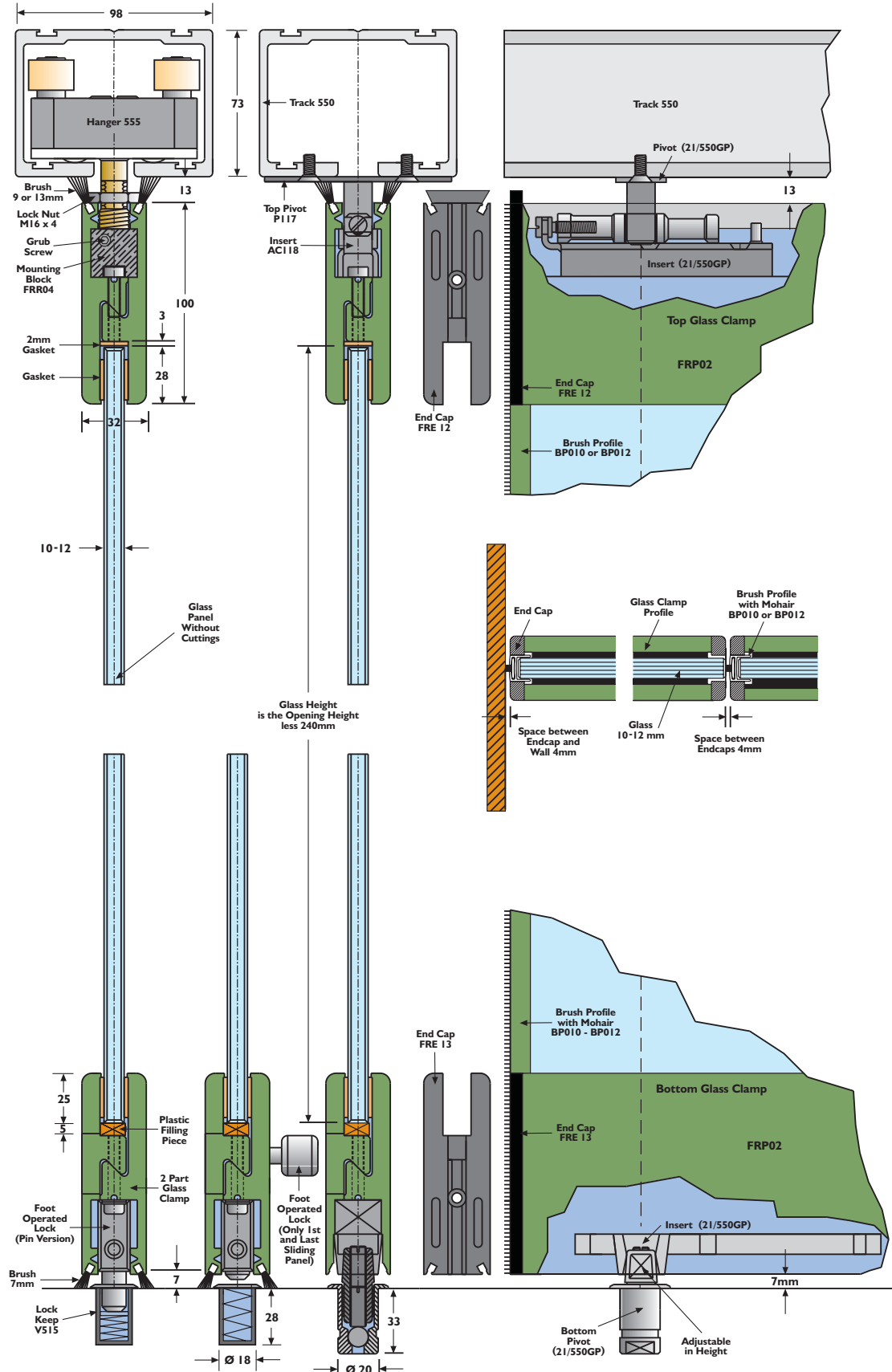

CAPACITY

Max. door weight:	100kg (2 hangers per leaf) 50kg (1 hanger per leaf)
Max. door height:	2800mm-10mm tempered glass 4000mm-12mm tempered glass
Max. door width:	1300mm-10mm tempered glass 1300mm-12mm tempered glass
Panel thickness:	10 or 12mm
Max. swing door width:	1200mm

APPLICATIONS

Lightweight glass partitions for internal and external applications requiring 90° movement.

DOOR TYPES

BS6206 toughened glass panels of 10 or 12mm thickness.

Note: when using glass clamps in combination with protective coatings for glass surfaces such as Clear Shield, ensure that the glass surface to be clamped is not treated with the Clear Shield coating.

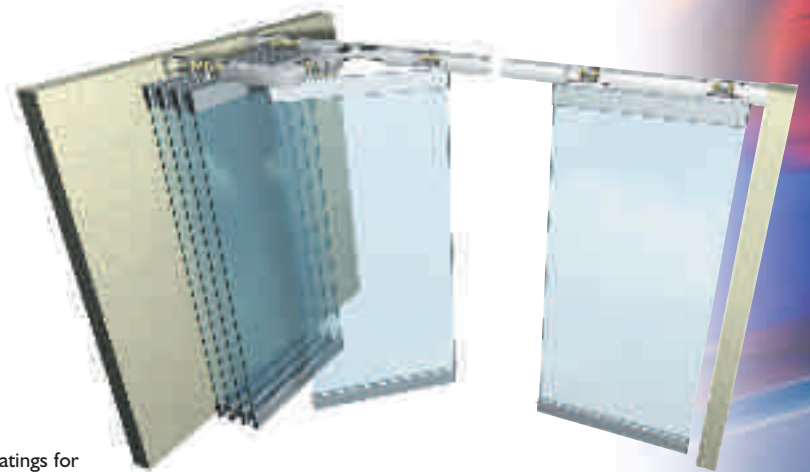

TECHNICAL INFORMATION

Track:	550 (extruded aluminium)		
Brackets:	Face fix	1A/550	
	Soffit fix	3S/550	
Hangers:	90° hanger	555	
Glass Profiles:	Top/bottom glass profile	FRP02	
	Swing/slide profile	FRP01	
Pivots:	Glass pivot set (top & bottom)	21/550GP	
Accessories:	Track stop	HH3/301	
	Door closers	Floor spring closer	7410
		Transom closer	5600
		(complete with 400mm of 550 track)	
	Swing/sliding floor spring	7305	
	Handle sets	H22/200 D - handle 22mm dia. 200mm long	
		H22/300 D - handle 22mm dia. 300mm long	
H33/220 D - handle 33mm dia. 220mm long			
H33/300 D - handle 33mm dia. 300mm long			
(Standard handle set finishes are silver anodised and white RAL9010. Other finishes are available on request.)			

90° Configurations

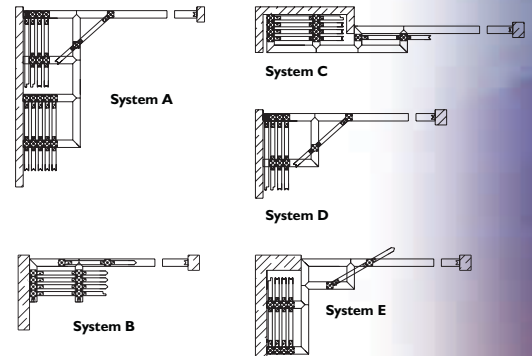

FLEXIROL 90°

MULTIDIRECTIONAL SYSTEM FOR GLASS DOORS

