

STRAIGHT SLIDING TOP HUNG

FIXING INSTRUCTIONS

BEFORE COMMENCING THE INSTALLATION, FIRSTLY READ THESE INSTRUCTIONS FROM BEGINNING TO END. REFERENCE CAN BE MADE TO THE APPROPRIATE HENDERSON DATA SHEET AND EXPERT SERVICE SCHEMATIC DRAWING AT ALL STAGES.

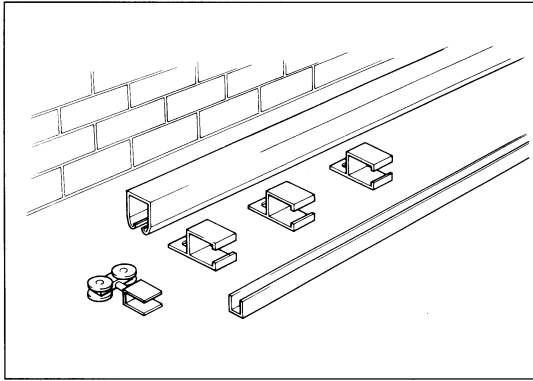

1 Ensure that you have all the required parts. Check the Bill of Materials supplied by the Expert Service. Unpack the components and identify the parts. Lay the parts on the ground in the same configuration as when installed. Ensure that the site is prepared to the best standard possible, to ensure easy installation and smooth operation of the doors.

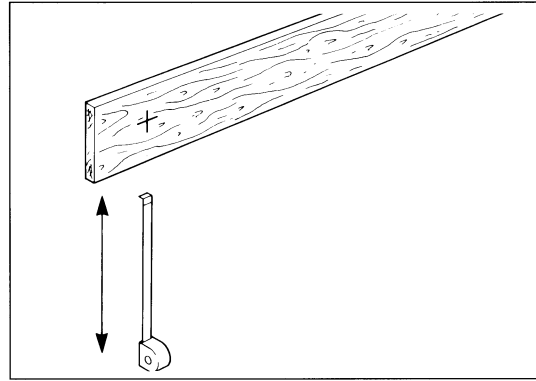

2 Begin the track installation by fixing the correct packing pieces where applicable. The next stage is to mark out the approximate centres of the brackets. Once the hole centres are marked out, loosely slide the brackets onto the track to be installed. Remember to install the end clips.

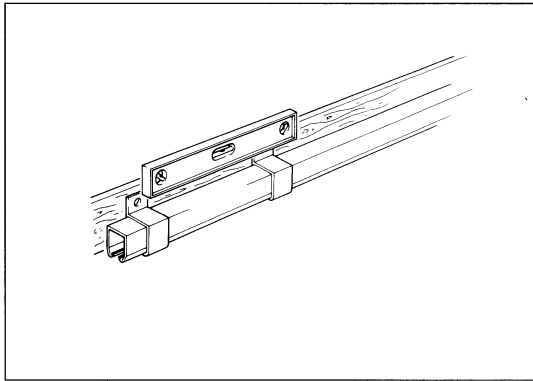

3 Offer up the track to the packing piece, loosely fix the end brackets and check alignment using spirit level. Joggle track to align then tighten up end brackets. From this evenly space out the brackets (no more than 900mm) along the length of track. Securely fix track and brackets into position.

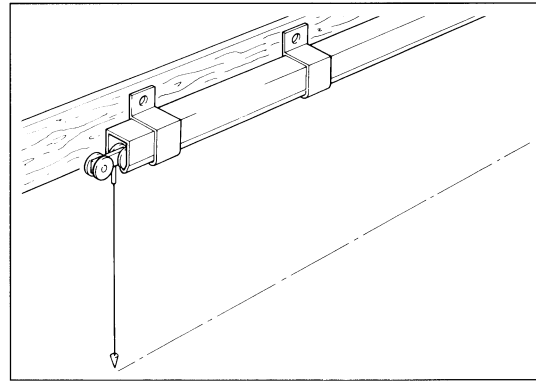

4 Attach a plumb line to a hanger. Loosen one of the end brackets and remove. Place the hanger inside the track. Using the plumb line mark out the centreline of the floor channel.

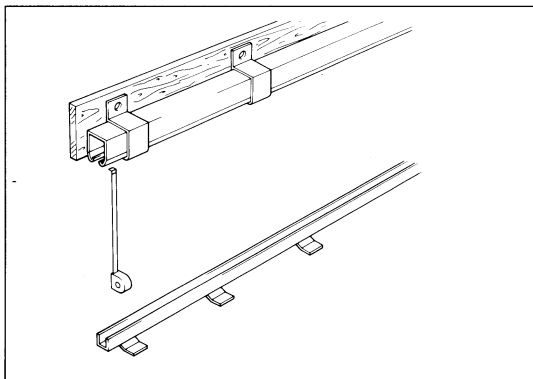

5 Attach the lugs and couplers to the floor channel, loosely fix the floor channel in position. It is recommended that the distance between track and floor channel is checked.

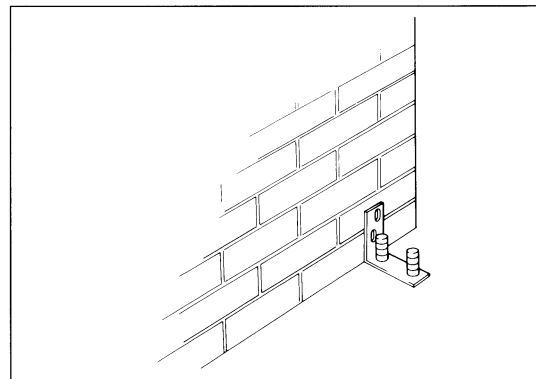

6 If using wall mounted guides then loosely attach these to the wall ensuring access to adjustment bolts.

STRAIGHT SLIDING TOP HUNG

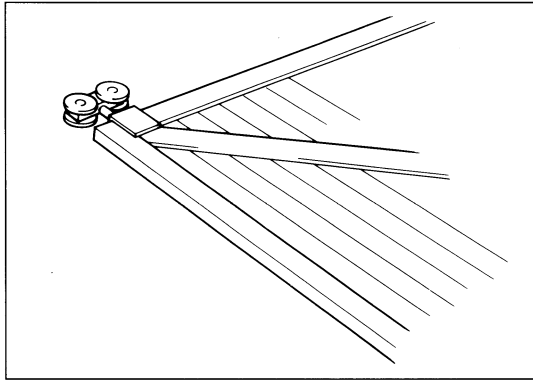

7 Remove the hanger and place back with the others. With the aid of a colleague lie a plastic sheet on the floor to protect the doors. Attach hangers, guides and hardware to doors, (ensure that all clearances are adhered to).

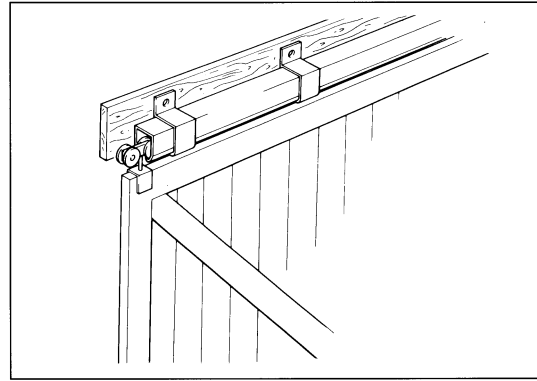

8 Offer up the assembled unit to the track ensuring that the hangers will locate straight into the track. Slowly guide the complete unit into the track and channel. Replace bracket onto the end of the track with the end clip in position. Check floor channel alignment and alter if required. Tighten in position. Move unit to the park position, attach wall stops to the correct height for the door.

Final adjustments

Visually check all bolts and screws, tighten if necessary. If access door is installed check operation. Check operation of doors for ease. If the following are happening:

- ▶ Door catches floor channel at one end - then check the track level with the spirit level and level up. Ensure that the track and floor channel are parallel to within +/-3mm from end to end.
- ▶ Door scrubs in channel - then check alignment of floor channel
- ▶ Door moves while in operation - then check hangers are fixed correctly

MANSION MAJESTIC

STRAIGHT SLIDING BOTTOM ROLLER

FIXING INSTRUCTIONS

All drawings refer to Mansion 55

BEFORE COMMENCING THE INSTALLATION, FIRSTLY READ THESE INSTRUCTIONS FROM BEGINNING TO END. REFERENCE CAN BE MADE TO THE APPROPRIATE HENDERSON DATA SHEET AND EXPERT SERVICE SCHEMATIC DRAWING AT ALL STAGES.

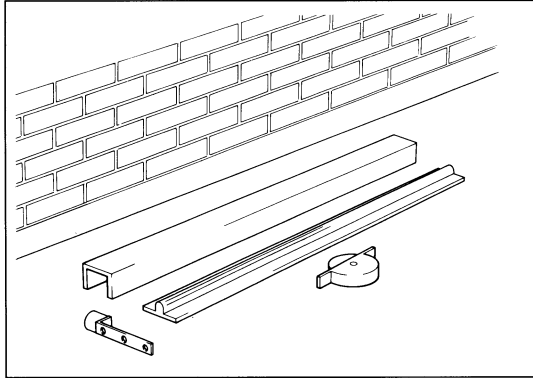

1 Ensure that you have all the required parts. Check the Bill of Materials supplied by the Expert Service. Unpack the components and identify the parts. Lay the parts on the ground in the same configuration as when installed. Ensure that the site is prepared to the best standard possible, to ensure easy installation and smooth operation of the doors.

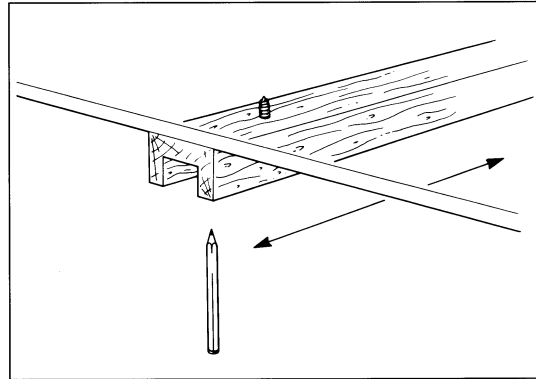

2 Begin the top guide channel installation by fixing the correct packing pieces where applicable. The next stage is to mark out the approximate centres of the brackets. Once the hole centres are marked out, slide the brackets onto the top guide channel to be installed. For Mansion 55 route out packing for channel and mark out the approximate centreline of the inverted channel.

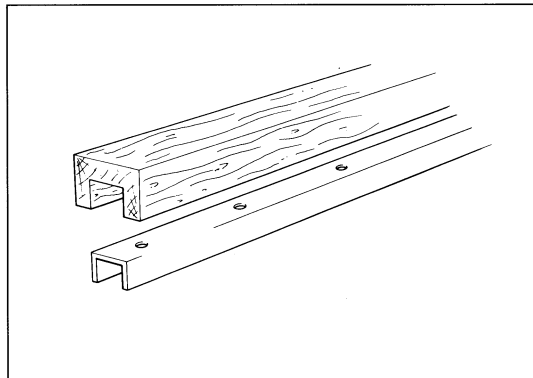

3 Offer up the top guide channel to the packing piece, loosely fix the end brackets and check alignment using spirit level. Joggle top guide channel to align then tighten up end brackets. From this evenly space out the brackets (no more than 900mm) along the length of top guide channel. Securely fix this into position. For Mansion 55 securely fix the inverted channel into position.

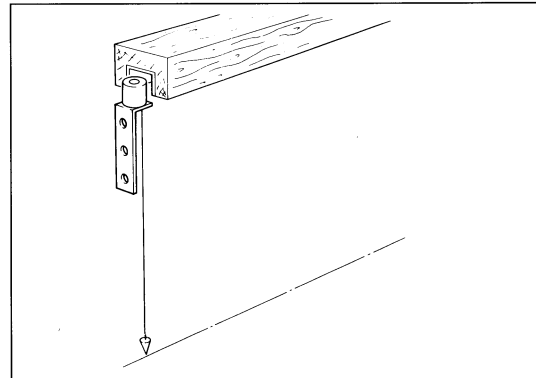

4 Attach a plumb line to the guide, then loosen one of the end brackets and remove. Place the guide inside the top guide channel. Using the plumb line mark out the centreline of the floor rail.

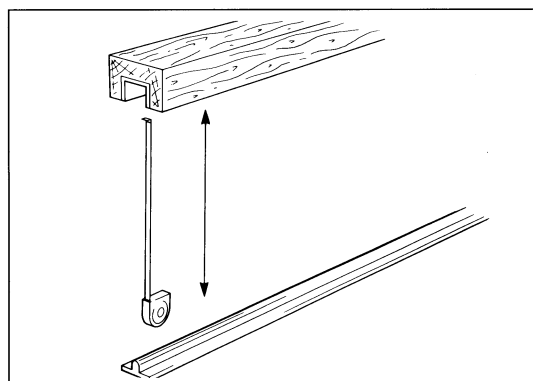

5 Loosely fix floor rail to floor, if required fix lugs and couplers to the floor rail before installation. Remove the guide and place back with others. It is recommended that the distance between top guide channel and floor rail is checked.

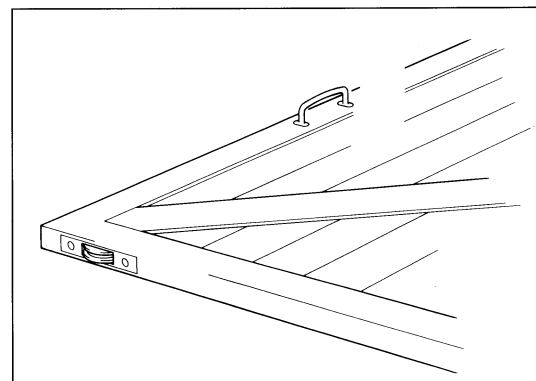

6 With the aid of a colleague lie a plastic sheet on the floor to protect the doors. Attach top guides, bottom rollers and all hardware to doors, (ensure that all clearances are adhered to).

MANSION MAJESTIC

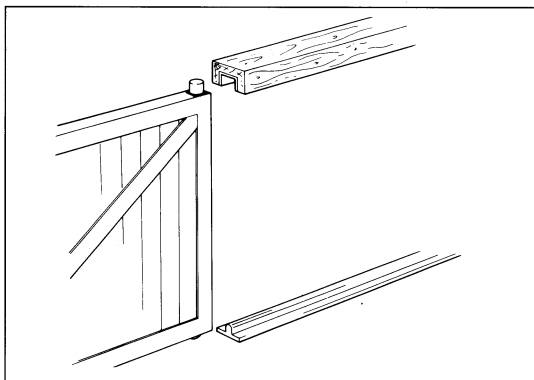

7 Offer up the assembled unit to the top guide channel. Slowly guide the bottom rollers onto the rail. Move complete unit, then replace bracket onto end of the top guide channel. Check bottom rail alignment and alter if required. Tighten in position.

Final adjustments

Visually check all bolts and screws, tighten if necessary. If access door is installed check operation. Check operation of doors for ease. If the following are happening:

- ▶ Door jams while in operation - then ensure that the top guide channel and floor rail are parallel to within +/-3mm from end to end.
- ▶ If the door is generally difficult to operate - then realign floor rail to top guide channel.

FIXING INSTRUCTIONS

BEFORE COMMENCING THE INSTALLATION, FIRSTLY READ THESE INSTRUCTIONS FROM BEGINNING TO END. REFERENCE CAN BE MADE TO THE APPROPRIATE HENDERSON DATA SHEET AND EXPERT SERVICE SCHEMATIC DRAWING AT ALL STAGES.

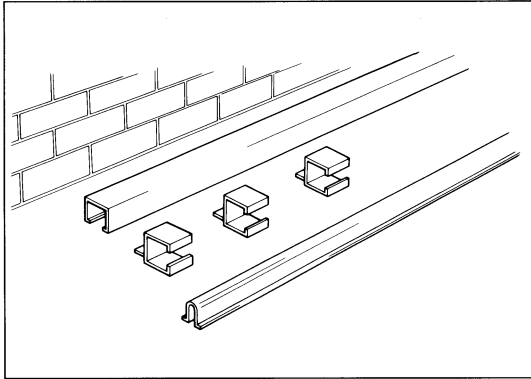

1 Ensure that you have all the required parts. Check the Bill of Materials supplied by the Expert Service. Unpack the components and identify the parts. Lay the parts on the ground in the same configuration as when installed. Ensure that the site is prepared to the best standard possible, to ensure easy installation and smooth operation of the doors.

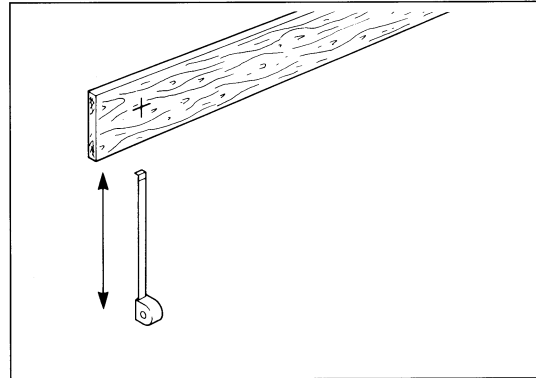

2 Begin the top guide channel installation by fixing the correct packing pieces where applicable. The next stage is to mark out the approximate centres of the brackets. Once the hole centres are marked out, loosely slide the brackets onto the top guide channel to be installed. Remember to install the end clips.

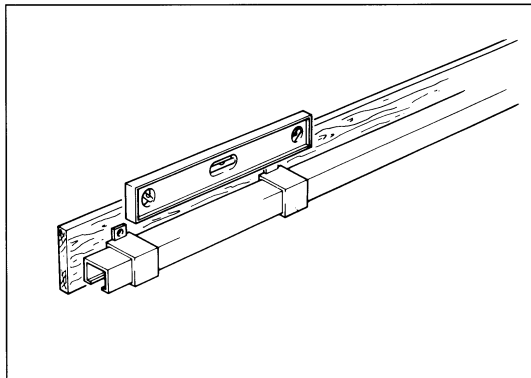

3 Offer up the top guide channel to the packing piece, loosely fix the end brackets and check alignment using spirit level. Joggle top guide channel to align then tighten up end brackets. From this evenly space out the brackets (no more than 900mm) along the length of top guide channel. Securely fix top guide channel and brackets into position.

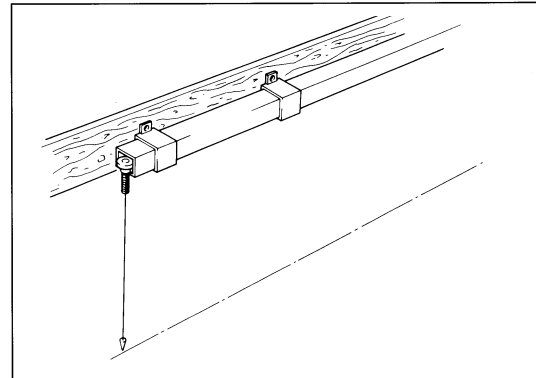

4 Attach a plumb line to a guide, then loosen one of the end brackets and remove. Place the guide inside the top guide channel, using the plumb line mark out the centreline of the floor rail.

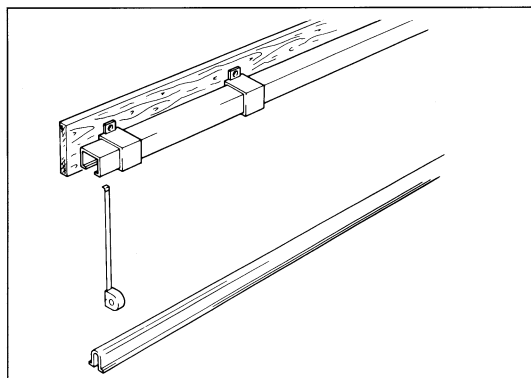

5 If required fix the lugs and couplers to the floor rail, loosely fix floor rail in position. It is recommended that the distance between top guide channel and floor rail is checked.

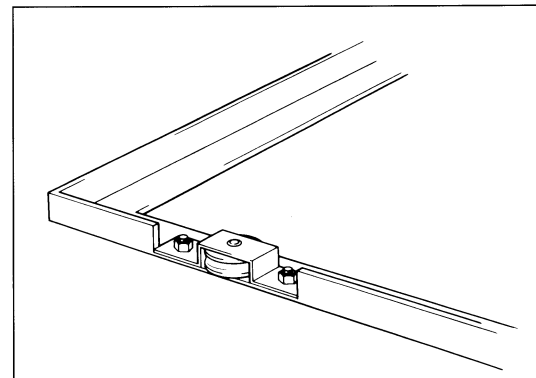

6 Remove the guide and place back with the others. With the aid of a colleague lie a plastic sheet on the floor to protect the doors. Attach top guides and bottom rollers and hardware to doors.

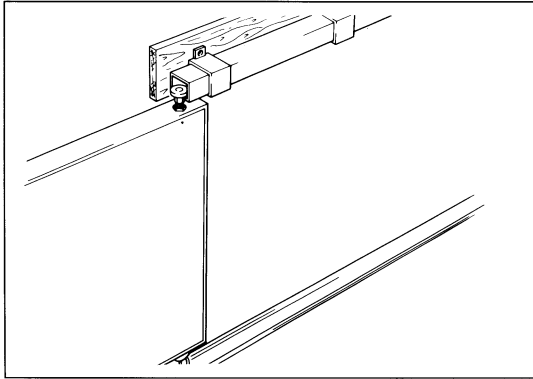

- 7 Offer up the assembled unit to the top guide channel. Slowly guide the bottom rollers onto the rail. Move complete unit, then replace bracket onto the end of the top guide channel. Check bottom rail alignment and alter if required. Tighten in position.

Final adjustments

Visually check all bolts and screws, tighten if necessary. If access door is installed check operation. Check operation of doors for ease. If the following are happening:

- ▶ Door jams while in operation - then ensure that the top guide channel and floor rail are parallel to within +/-3mm from end to end.
- ▶ If the door is generally difficult to operate - then realign floor rail to top guide channel.

TANGENT ROUND THE CORNER

ROUND THE CORNER STRAIGHT SLIDING TOP HUNG

FIXING INSTRUCTIONS

BEFORE COMMENCING THE INSTALLATION, FIRSTLY READ THESE INSTRUCTIONS FROM BEGINNING TO END. REFERENCE CAN BE MADE TO THE APPROPRIATE HENDERSON DATA SHEET AND EXPERT SERVICE SCHEMATIC DRAWING AT ALL STAGES.

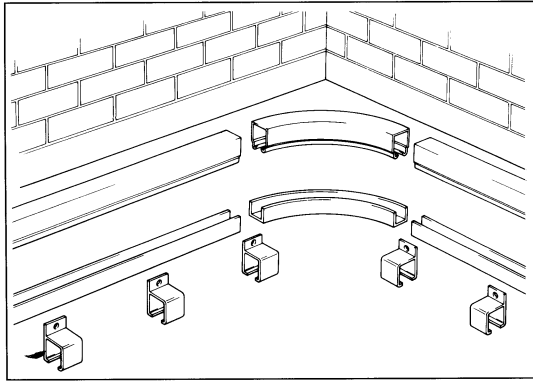

1 Ensure that you have all the required parts. Check the Bill of Materials supplied by the Expert Service. Unpack the components and identify the parts. Lay the parts on the ground in the same configuration as when installed. Ensure that the site is prepared to the best standard possible, to ensure easy installation and smooth operation of the doors.

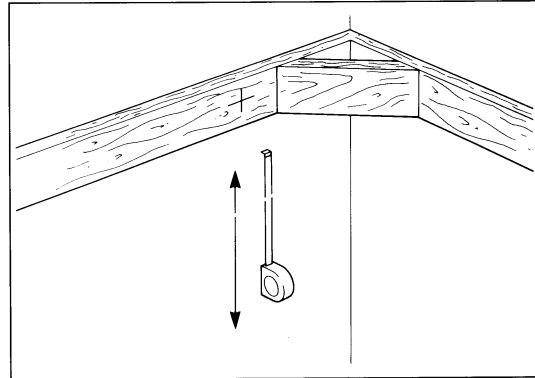

2 Begin the track installation by fixing the correct packing along the sidewall and across the face of the opening. The next stage is to mark out the approximate centres of the brackets. Once the hole centres are marked out, loosely place the brackets onto the track to be installed. If installing 301, do not forget the 4RX/301TS brackets, and the end clips.

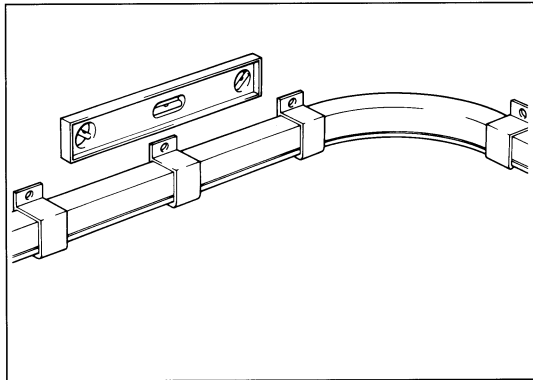

3 Offer up the track to the packing piece, loosely fix the end brackets and check alignment using spirit level. Joggle track to align and tighten up end brackets. From this evenly space out the brackets (no more than 900mm) along the length of track. Securely fix track and brackets into position.

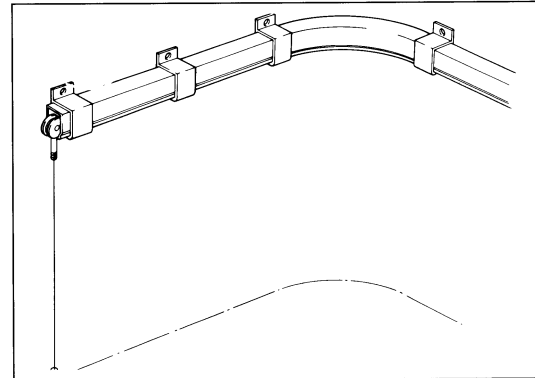

4 Attach a plumb line to a hanger, then loosen one of the end brackets and remove. Place the hanger inside the track. Using the plumb line mark out the centreline of the floor channel.

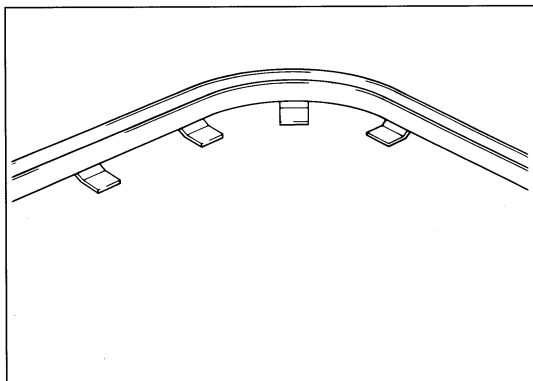

5 If required fix the lugs and couplers to the floor channel, loosely fix the floor channel.

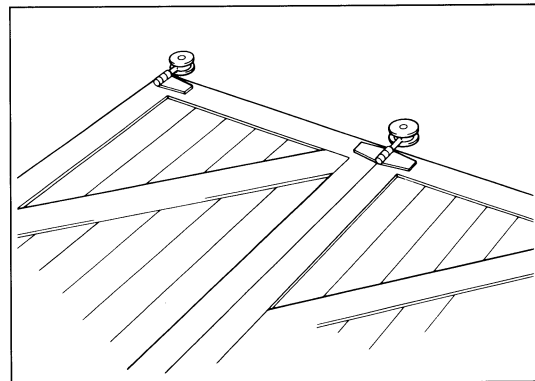

6 Remove the hanger and place back with others. With the aid of a colleague lie a plastic sheet on the floor to protect the doors. Attach hangers, guides and hardware to the doors, (ensure that all clearances are adhered to).

TANGENT ROUND THE CORNER

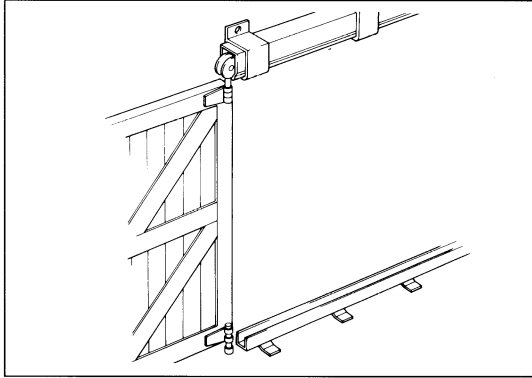

7 Offer up the assembled unit to the track ensuring that the hangers will locate straight into the track. Slowly guide the complete unit into the track and channel. Replace bracket onto the end of the track with the end clip in position. Check floor channel alignment and alter if required. Tighten in position. Move unit to the park position, attach wall stops to the correct height for the door.

Final adjustments

Visually check all bolts and screws, tighten if necessary. If access door is installed check operation. Check operation of doors for ease. If the following are happening:

- ▶ Door jams on the curve - then check that the door width is within the required tolerance. Check that the side wall is square.*
- ▶ Guides lift out of floor channel, or door guides catch floor channel at one end - then check the track level with spirit level and level up. Ensure that the track and floor channel are parallel to within +/-3mm from end to end.
- ▶ Door operates with difficulty - then realign floor channel to track.
- ▶ Hangers work loose - then check the locknut.

*To check for side wall angularity: Measure 914mm along front wall and mark. Measure 914mm along sidewall and mark. The required tolerance is 2 degrees from square or 1282mm to 1300mm between the marks. If the dimension is outside this range please contact PC Henderson for further advice.

TANGENT FOLDING

EXTERNAL FOLDING DOORS TOP HUNG

FIXING INSTRUCTIONS

BEFORE COMMENCING THE INSTALLATION, FIRSTLY READ THESE INSTRUCTIONS FROM BEGINNING TO END. REFERENCE CAN BE MADE TO THE APPROPRIATE HENDERSON DATA SHEET AND EXPERT SERVICE SCHEMATIC DRAWING AT ALL STAGES.

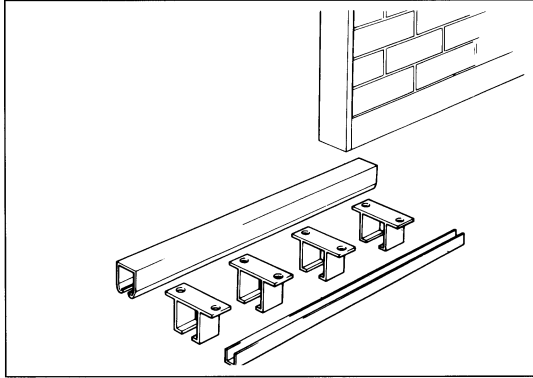

1 Ensure that you have all the required parts. Check the Bill of Materials supplied by the Expert Service. Unpack the components and identify the parts. Lay the parts on the ground in the same configuration as when installed. Ensure that the site is prepared to the best standard possible, to ensure easy installation and smooth operation of the doors.

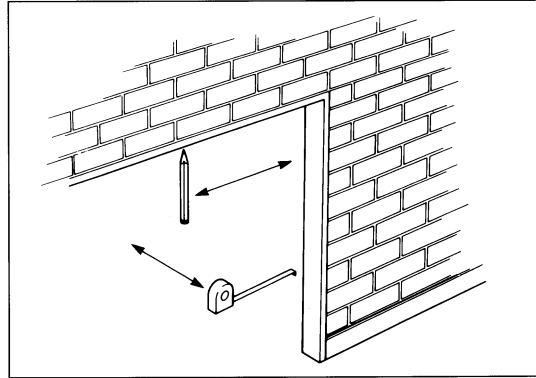

2 Begin the track installation by fixing the correct packing pieces where applicable. The next stage is to mark out the approximate centres of the brackets. Once the hole centres are marked out loosely slide the brackets onto the track to be installed. Remember to install the end clips.

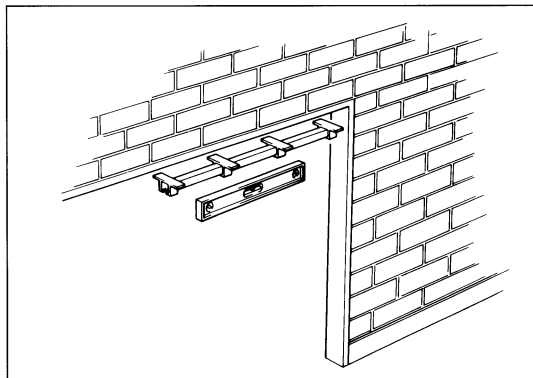

3 Offer up the track to the packing piece, loosely fix the end brackets and check alignment using spirit level. Joggle track to align then tighten up end brackets. From this evenly space out the brackets (no more than 900mm) onto the length of the track. Securely fix track and brackets into position. As the last piece of track is installed, insert a hanger into it. Securely fix brackets in place.

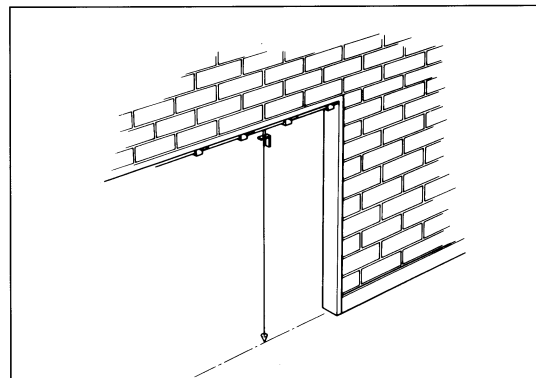

4 Attach a plumb line to the hanger. Using the plumb line mark out the centreline of the floor channel.

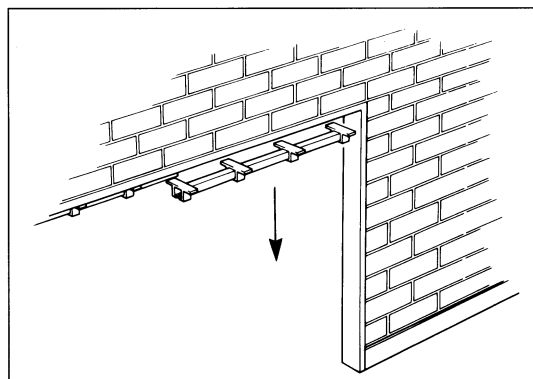

5 If installing a unit hinged to post, remove the section of track at the opposite end to the post.

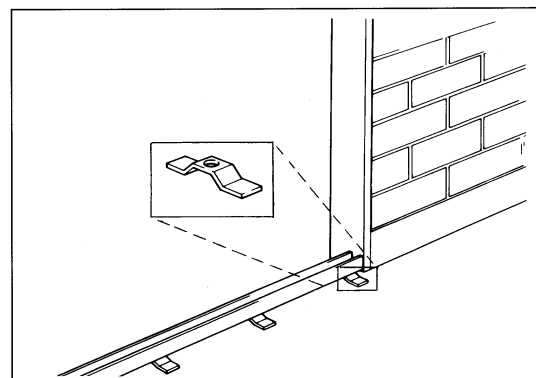

6 Attach lugs and couplers to the floor channel, loosely fix the floor channel in position.

HENDERSON

TANGENT FOLDING

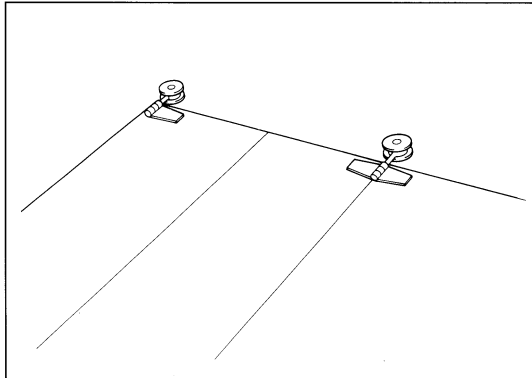

7 With the aid of a colleague lie a plastic sheet on the floor to protect the doors. Attach all hangers, guides and hardware to doors, (ensure that all clearances are adhered to).

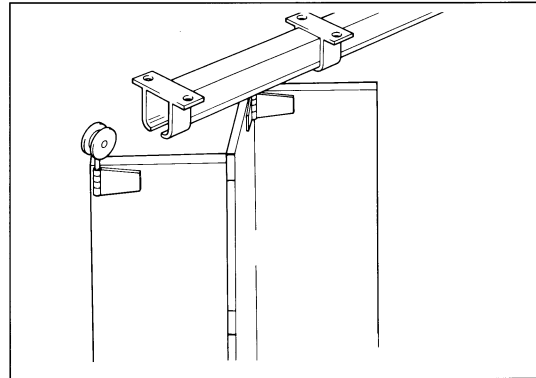

8 Offer up the assembled unit to the track ensuring that the hangers will locate straight into the track. Slowly guide the complete unit into the track and channel. Slide the complete unit to the closed position, adjust the hangers to the correct clearances and tighten lock nut. Hinge the unit to the required side of the opening.

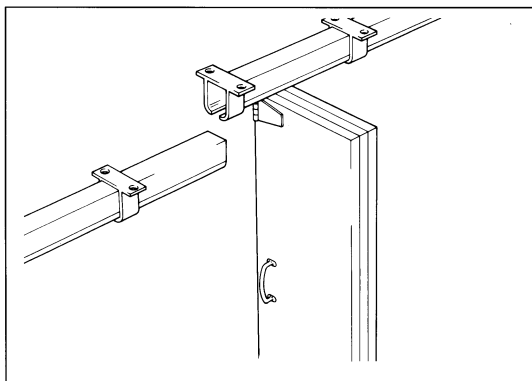

9 Replace the section of track removed earlier. Check track alignment and alter if required. Tighten in position.

Final adjustments

Visually check all bolts and screws, tighten if necessary. If access door is installed check operation. Check operation of doors for ease. If the following are happening:

- ▶ Doors will not fold correctly - then leaf widths may be incorrect and calculations should be checked. Also the end guide may not be set correctly.
- ▶ Hanger works loose after several operations - then tighten locknut.
- ▶ Guides lift out of floor channel. or door guides catch floor channel at one end - then check the track level with the spirit level and level up. Ensure that the track and floor channel are parallel to within +/-3mm from end to end.
- ▶ Doors are hard to operate - then realign floor channel to track.

CENTREFOLD PARTITION

INTERNAL FOLDING DOORS TOP HUNG

FIXING INSTRUCTIONS

BEFORE COMMENCING THE INSTALLATION, FIRSTLY READ THESE INSTRUCTIONS FROM BEGINNING TO END. REFERENCE CAN BE MADE TO THE APPROPRIATE HENDERSON DATA SHEET AND EXPERT SERVICE SCHEMATIC DRAWING AT ALL STAGES.

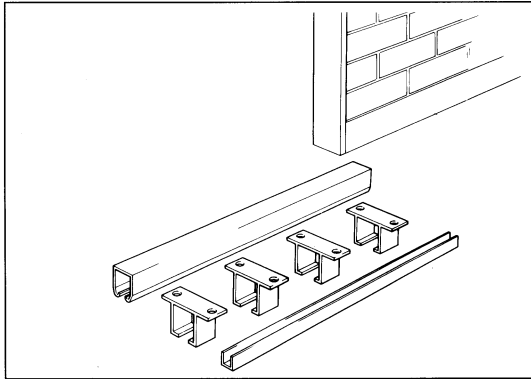

1 Ensure that you have all the required parts. Check the Bill of Materials supplied by the Expert Service. Unpack the components and identify the parts. Lay the parts on the ground in the same configuration as when installed. Ensure that the site is prepared to the best standard possible, to ensure easy installation and smooth operation of the doors.

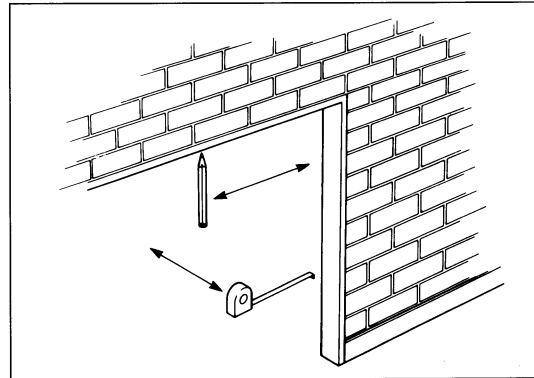

2 Begin the track installation by fixing the correct packing pieces where applicable. The next stage is to mark out the approximate centres of the brackets. Once the hole centres are marked loosely slide the brackets onto the track to be installed. Remember to install the end clips.

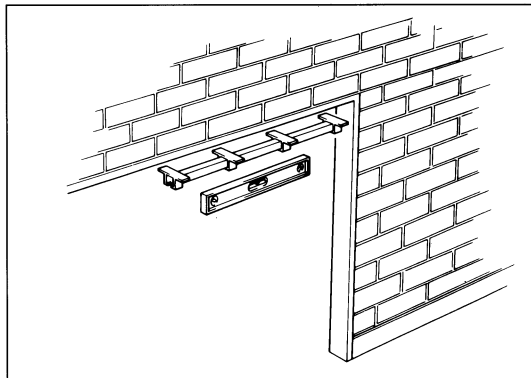

3 Offer up the track to the packing piece, loosely fix the end brackets and check alignment using spirit level. Joggle track to align then tighten up end brackets. From this evenly space out the brackets (no more than 900mm) along the length of track. Securely fix track and brackets into position. Before the last piece of track is installed, insert a hanger into it. Securely fix brackets in place.

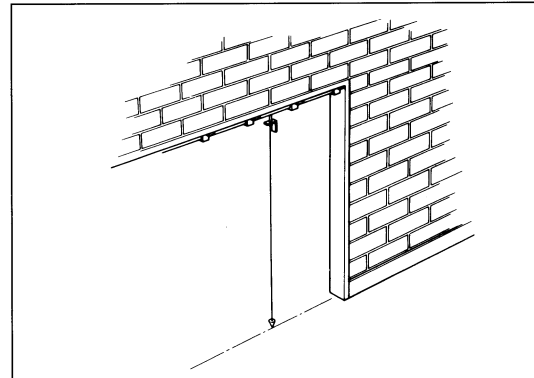

4 Attach a plumb line to the hanger. Using the plumb line mark out the centreline of the floor channel.

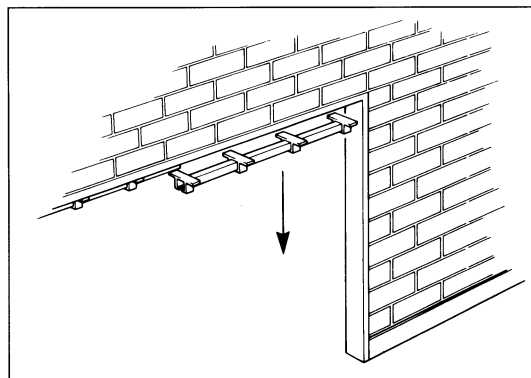

5 If installing one hinged unit then remove the section of the track opposite to the hinged side. It is recommended that the distance between track and floor channel is checked.

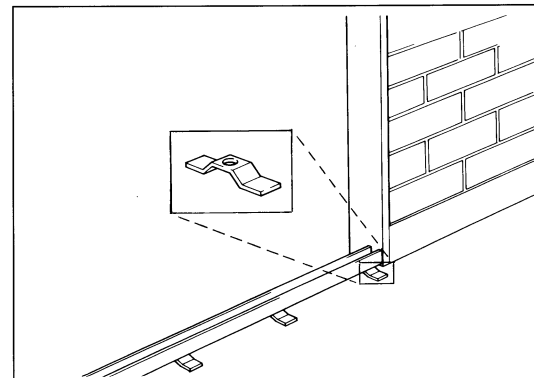

6 Attach lugs and couplers to the floor channel, loosely fix the floor channel in position.

HENDERSON

CENTREFOLD PARTITION

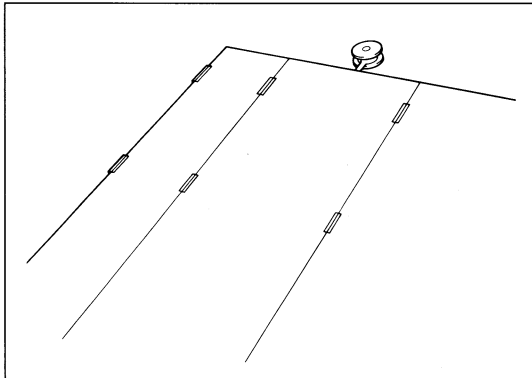

7 With the aid of a colleague lie a plastic sheet on the floor to protect the doors. Attach hangers, guides and hardware to doors, (ensure that all clearances are adhered to).

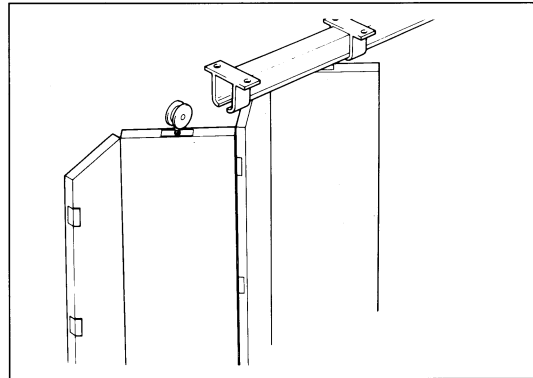

8 Offer up the assembled unit to the track ensuring that the hangers will locate into the track. Slowly guide the complete unit into the track and channel. Slide the complete unit to the closed position, adjust the hangers to the correct clearances and tighten lock nut. Hinge the unit to the required side of the opening.

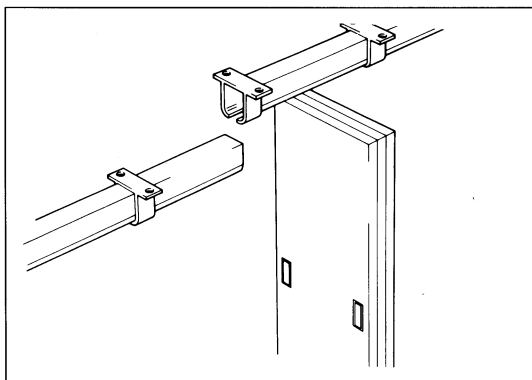

9 Replace the section of track removed earlier. Check floor channel alignment and alter if required. Tighten in position.

Final adjustments

Visually check all bolts and screws, tighten if necessary. If access door is installed check operation. Check operation of doors for ease. If the following are happening:

- ▶ Doors will not fold correctly - then leaf widths may be incorrect and calculations should be checked. Also the end guide may not be set correctly.
- ▶ Hanger works loose after several operations - then tighten locknut.
- ▶ Guides lift out of floor channel. or door guides catch floor channel at one end - then check the track level with the spirit level and level up. Ensure that the track and floor channel are parallel to within +/-3mm from end to end.
- ▶ Doors are hard to operate - then realign floor channel to track.

ENDFOLD & PIVOT PARTITION

INTERNAL FOLDING DOORS TOP HUNG

FIXING INSTRUCTIONS

BEFORE COMMENCING THE INSTALLATION, FIRSTLY READ THESE INSTRUCTIONS FROM BEGINNING TO END. REFERENCE CAN BE MADE TO THE APPROPRIATE HENDERSON DATA SHEET AND EXPERT SERVICE SCHEMATIC DRAWING AT ALL STAGES.

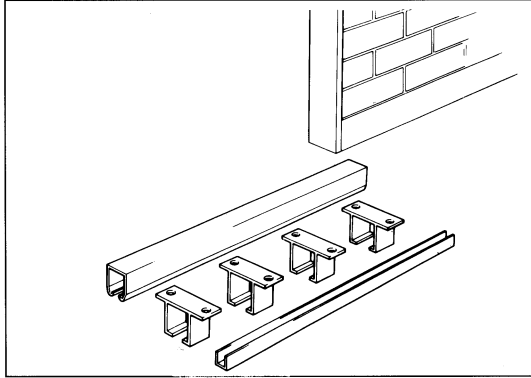

❶ Ensure that you have all the required parts. Check the Bill of Materials supplied by the Expert Service. Unpack the components and identify the parts. Lay the parts on the ground in the same configuration as when installed. Ensure that the site is prepared to the best standard possible, to ensure easy installation and smooth operation of the doors.

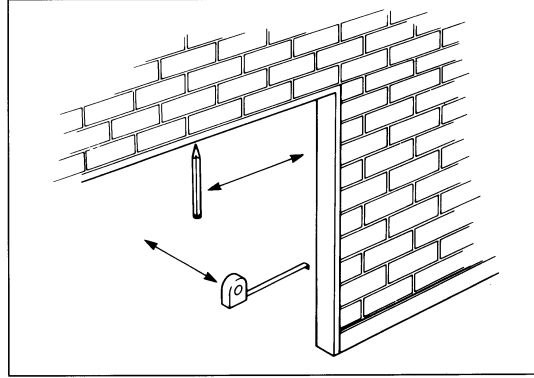

❷ Begin the track installation by fixing the correct packing pieces where applicable. The next stage is to mark out the approximate centres of the brackets. Once the hole centres are marked out loosely slide the brackets onto the track to be installed. Remember to install the end clips.

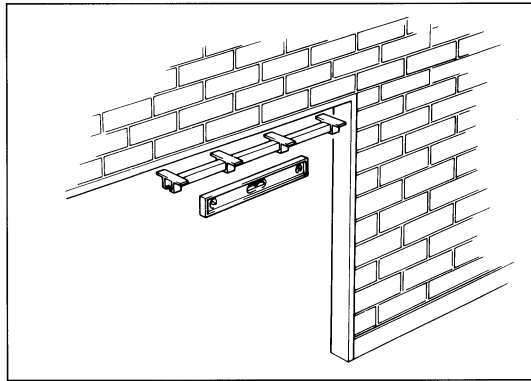

❸ Offer up the track to the packing piece, loosely fix the end brackets and check alignment using spirit level. Joggle track to align then tighten up end brackets. From this evenly space out the brackets (no more than 900mm) onto the length of track. Securely fix track and brackets into position. Before the last piece of track is installed, insert a hanger into it. Securely fix brackets in place.

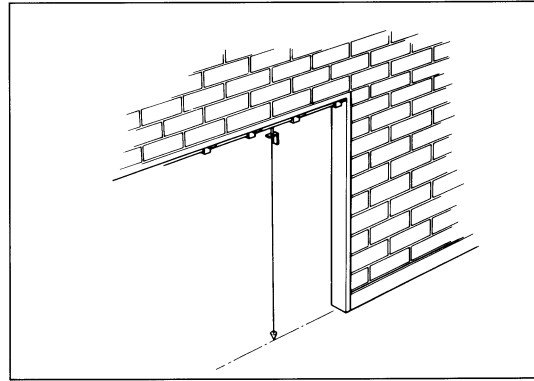

❹ Attach a plumb line to the hanger. Using the plumb line mark out the centreline of the floor channel.

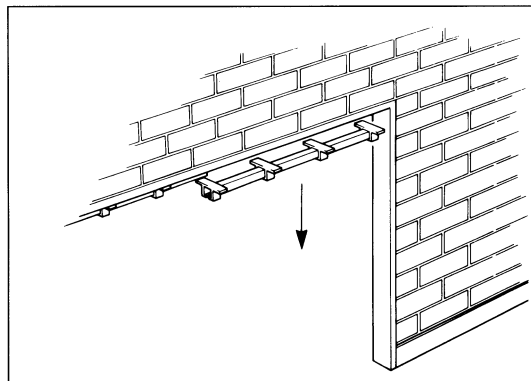

❺ If installing a unit hinged to post, remove the section of track at the opposite end to the post.

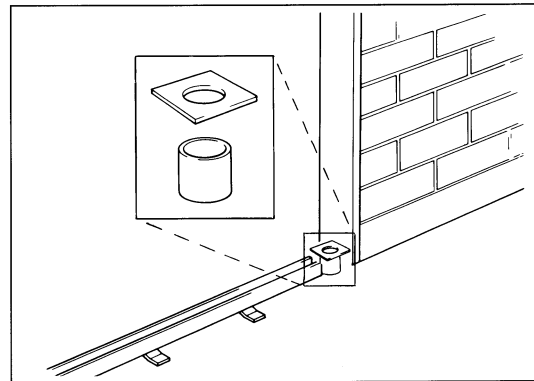

❻ Attach lugs and couplers to the required floor channel, loosely fix the floor channel in position. It is recommended that the distance between track and floor channel is checked. If installing pivot gear, ensure that the socket is positioned correctly at the end of the floor channel.

HENDERSON

ENDFOLD & PIVOT PARTITION

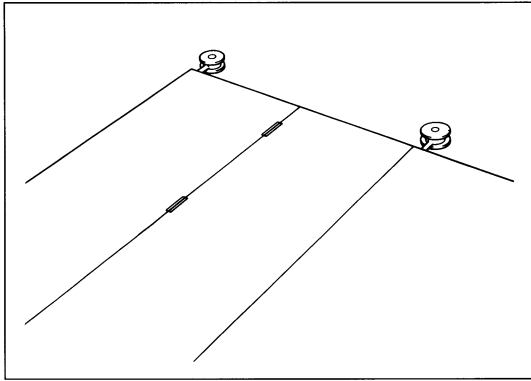

7 With the aid of a colleague lie a plastic sheet on the floor to protect the doors. Attach hangers, guides and hardware to doors, (ensure that all clearances are adhered to).

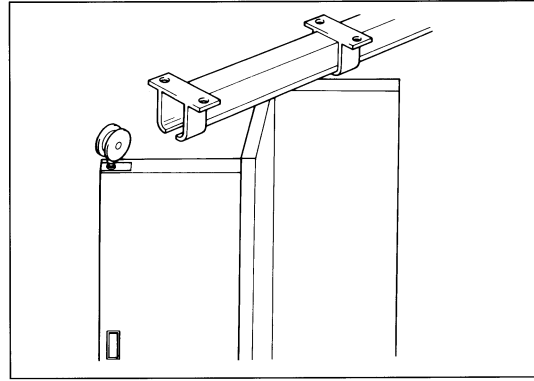

8 Offer up the assembled unit to the track ensuring that the hangers will locate into the track. Slowly guide the complete unit into the track and channel. Slide the complete unit to the closed position, adjust the hangers to the correct clearances and tighten lock nut. Hinge the unit to the required side of the opening.

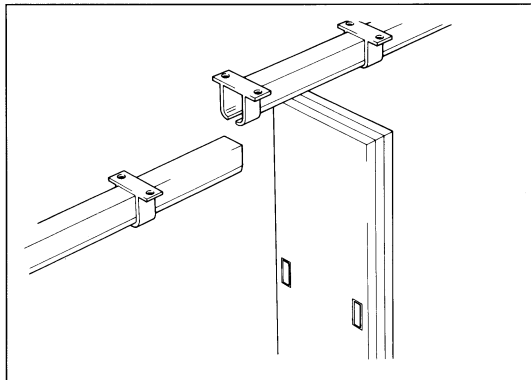

9 Replace the section of track removed earlier. Check floor channel alignment and alter if required. Tighten in position.

Final adjustments

Visually check all bolts and screws, tighten if necessary. If access door is installed check operation. Check operation of doors for ease. If the following are happening:

- ▶ Doors will not fold correctly - then leaf widths may be incorrect and calculations should be checked. Also the end guide may not be set correctly.
- ▶ Hanger works loose after several operations - then tighten locknut.
- ▶ Guides lift out of floor channel, or door guides catch floor channel at one end - then check the track level with the spirit level and level up. Ensure that the track and floor channel are parallel to within ± 3 mm from end to end.
- ▶ Doors are hard to operate - then realign floor channel to track.

COLLEGE ENDFOLD AND CENTREFOLD

STRAIGHT SLIDING TOP HUNG METAL GATES

FIXING INSTRUCTIONS

BEFORE COMMENCING THE INSTALLATION, FIRSTLY READ THESE INSTRUCTIONS FROM BEGINNING TO END. REFERENCE CAN BE MADE TO THE APPROPRIATE HENDERSON DATA SHEET AND EXPERT SERVICE SCHEMATIC DRAWING AT ALL STAGES.

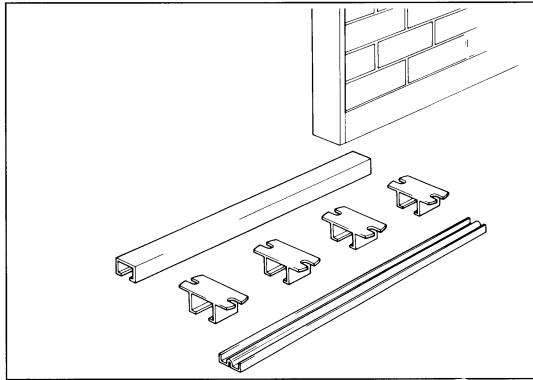

1 Ensure that you have all the required parts. Check the Bill of Materials supplied by the Expert Service. Unpack the components and identify the parts. Lay the parts on the ground in the same configuration as when installed. Ensure that the site is prepared to the best standard possible, to ensure easy installation and smooth operation of the doors.

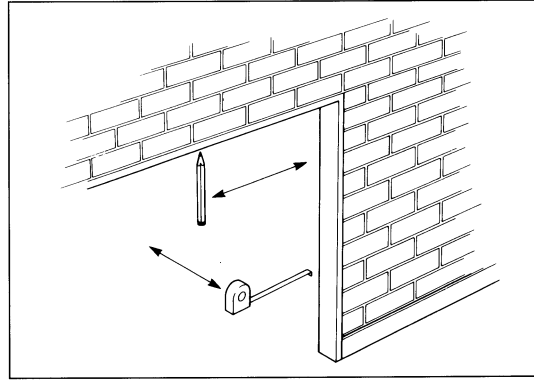

2 Begin the top guide channel installation by fixing the correct packing pieces where applicable. The next stage is to mark out the approximate centres of the brackets. Once the hole centres are marked out loosely slide the brackets onto top guide channel to be installed. Remember to install the end clips.

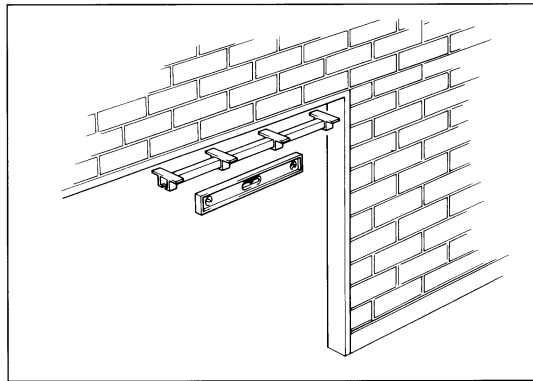

3 Offer up the top guide channel to the packing piece, loosely fix the end brackets and check alignment using spirit level. Joggle top guide channel to align then tighten up end brackets. From this evenly space out the brackets (no more than 900mm) along the length of top guide channel. Securely fix top guide channel and brackets into position. As the last piece of top guide channel is installed, insert a guide into it. Securely fix brackets in place.

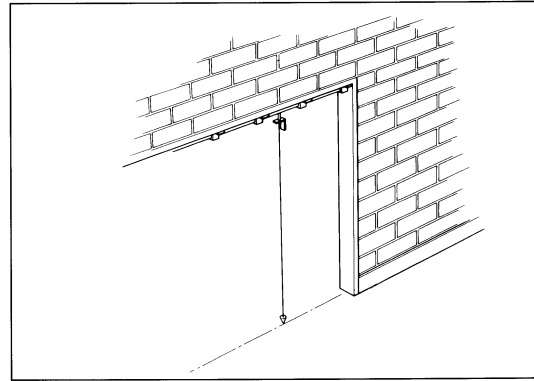

4 Attach a plumb line to the guide. Using the plumb line mark out the centreline of the floor rail.

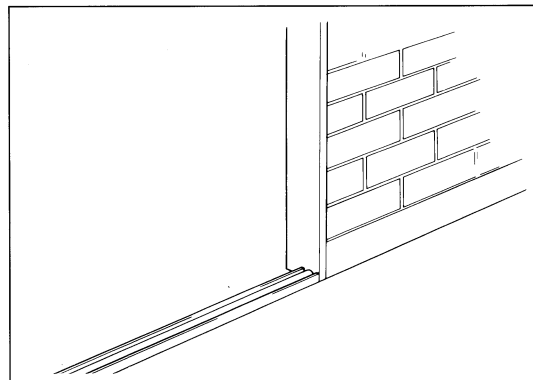

5 Attach lugs and couplers to the floor rail, loosely fix the floor rail in position. It is recommended that the distance between the top guide channel and the floor rail is checked.

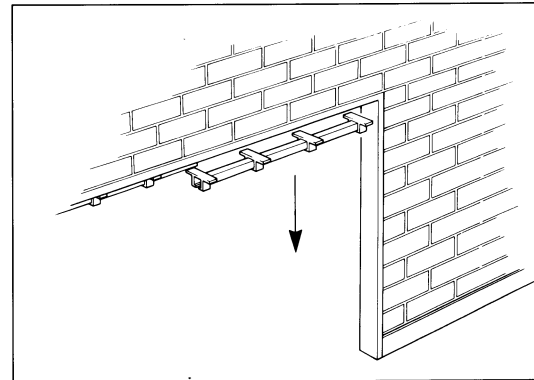

6 If installing a unit hinged to post, remove the section of the top guide channel at the opposite end to the post.

COLLEGE ENDFOLD & CENTREFOLD

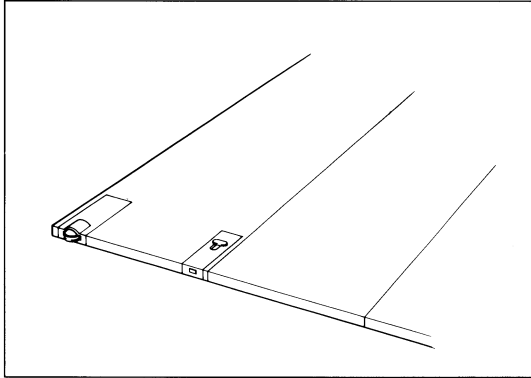

7 With the aid of a colleague lie a plastic sheet on the floor to protect the doors. Attach top guides, bottom rollers and hardware to doors, (ensure that all clearances are adhered to).

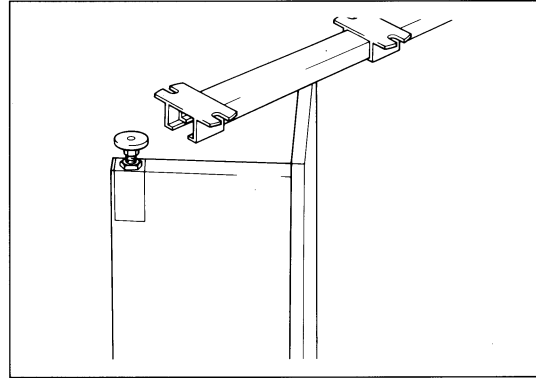

8 Offer up the assembled unit to the top guide channel ensuring that the bottom rollers are located onto the floor rail. Slowly guide the complete unit onto the rail and into the top guide channel. Slide the complete unit to the closed position, adjust the guides to the correct clearances and tighten lock nut. Hinge the unit to the required side of the opening.

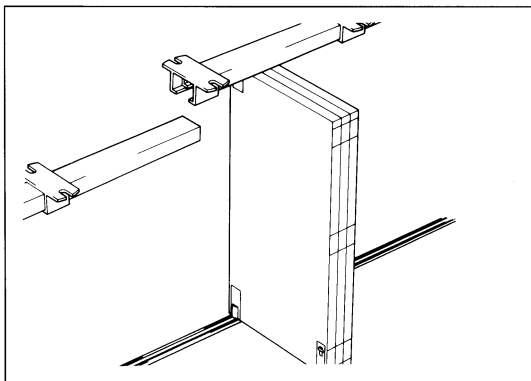

9 Replace the section of top guide channel removed earlier, check floor rail alignment and alter if required. Tighten in position.

Final adjustments

Visually check all bolts and screws, tighten if need be. If access door is installed check operation. Check operation of doors for ease. If the following are happening:

- ▶ Doors will not fold correctly - then leaf widths may be incorrect and calculations should be checked. Also the end guide may not be set correctly.
- ▶ Doors lean to one side during stacking - then check that cover fillets are installed correctly.
- ▶ Doors are hard to operate - then realign floor rail to top guide channel.
- ▶ Bottom rollers leave rail - then check top guide channel with the spirit level and level up. Ensure that the top guide channel and floor rail are parallel to within +/- 3mm from end to end.