

HENDERSON MARATHON

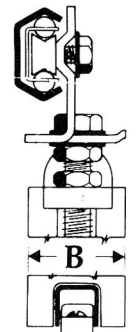

- J2 A = 400 - 750mm 55kg
- J3 A = 750 - 900mm 55kg
- J4 A = 900 - 1050mm 55kg
- J5 A = 1050 - 1200mm 55kg
- J6 A = 1200 - 1500mm 55kg

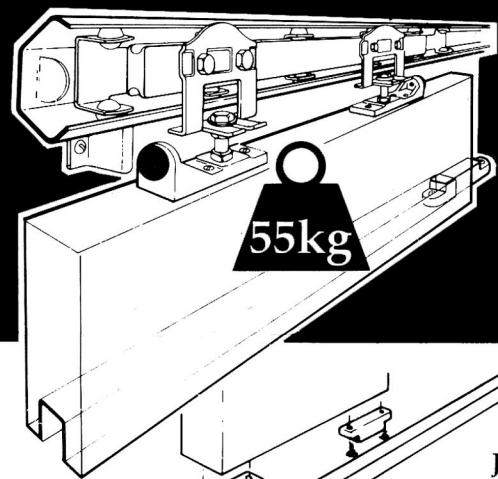
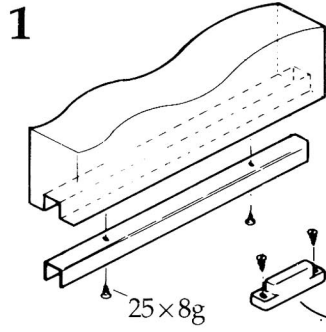
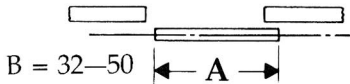

- J2
- J3
- J4
- J5

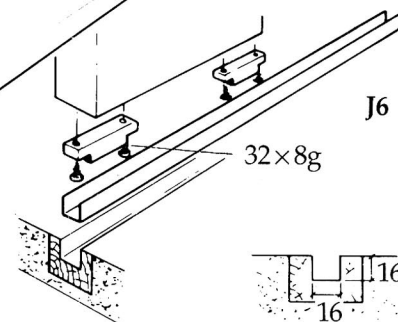

2

	mm	
	A	E
J2	400 - 750	267
J3	750 - 900	368
J4	900 - 1050	445
J5	1050 - 1200	546
J6	1200 - 1500	724

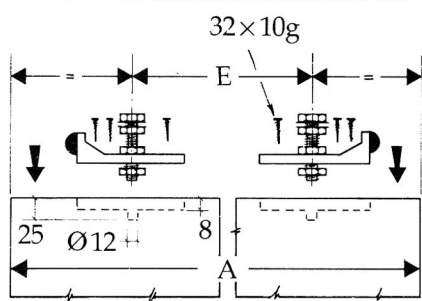

3

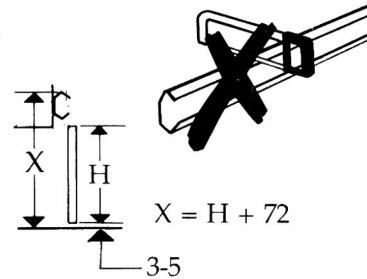
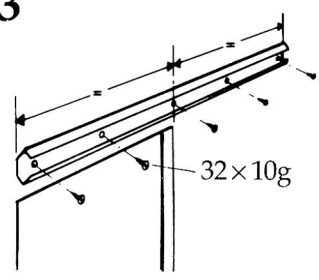

4

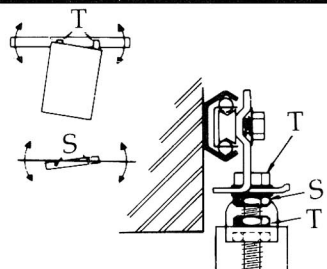
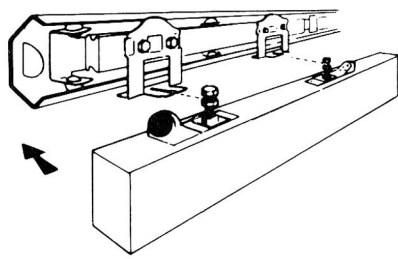

5

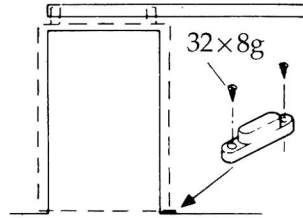

6

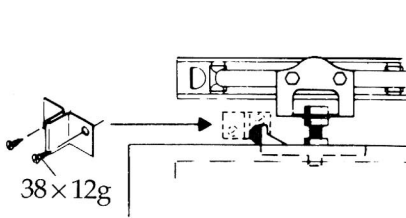

LUBRICATION INSTRUCTION

USING THE SACHET OF LUBRICANT SUPPLIED, APPLY LUBRICANT TO MARATHON ASSEMBLY BETWEEN TRACK AND BALLS.

RE-LUBRICATION - THE TRACK SHOULD BE RE-LUBRICATED AT REGULAR INTERVALS DEPENDING ON USE.

LUBRICANT INFORMATION

LUBRICANT - ANTI-SEIZE COMPOUND (POLYBUTYLSEPISE)
 CHEMICAL FAMILY - MINERAL OIL BASE
 HEALTH EFFECTS - EYES: IRRITATION CAN OCCUR.
 SKIN: IRRITATION CAN OCCUR.
 INGESTION: PRODUCES GASTRO-INTESTINAL DISTURBANCES.

FIRST AID - EYES: WASH WITH WATER AND CONSULT MEDICAL PRACTITIONER.
 SKIN: WASH WITH WARM WATER + SOAP.
 INGESTION: CALL MEDICAL PRACTITIONER IMMEDIATELY.
 INHALATION: BRING SUBJECT INTO FRESH AIR (CONSULT A MEDICAL PRACTITIONER)