

design features

- ▶ individual door weights of up to 100kg
- ▶ straight sliding or folding doors
- ▶ pre-drilled track, permitting face fixing or soffit fixing
- ▶ jump-proof tracks to prevent door coming off track
- ▶ height adjustment for precise fit
- ▶ top hanging or bottom rolling options
- ▶ nylon or steel wheel options to cater for all loadings
- ▶ fire resistant designs available
- ▶ corrosion-free aluminium or galvanised track for smooth operation



H

E

N

D

E

R

S

O

N

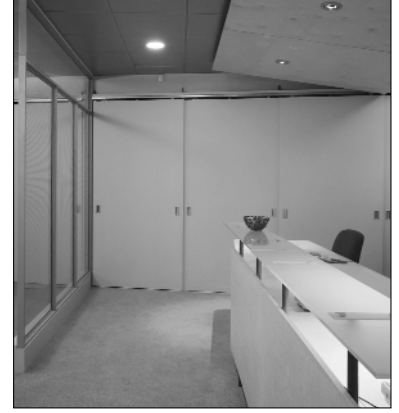

domestic sliding gear

Typical applications for domestic gear are on sliding doors in domestic or light-use commercial interiors.

For example - cabinets, cupboards, wardrobes, interior doors and room dividers.

Sliding doors save room space as the door does not require a swing space to open. Using sliding doors therefore makes perfect sense where space is at a premium.

Henderson domestic sliding gear is designed and engineered with particular attention to aesthetic appearance, smooth and silent operation and ease of installation.

Domestic sliding gear is supplied in standard individual kits.



All the necessary parts and fixing instructions are included in each kit, making the selection and fitting of every installation a simple task.

**FOR SLIDING
CUPBOARD
DOORS TO 9KG**

SLIPPER

For opening widths to	2 door kit no.
1200mm	SS4
1500mm	SS5
1800mm	SS6
Optional 1 door fittings kit	SS1
Cupboard door lock	no. 29I
Flushpull	no. 26P
Max leaf size	1800 x 900 x 30mm
Max leaf weight	9kg

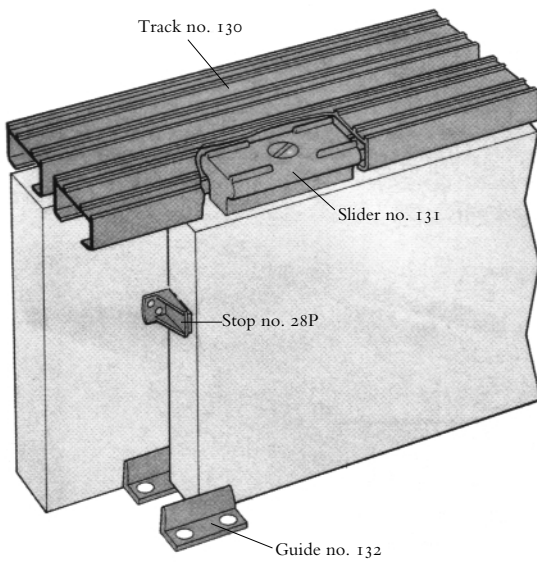

SOFFIT FIXED

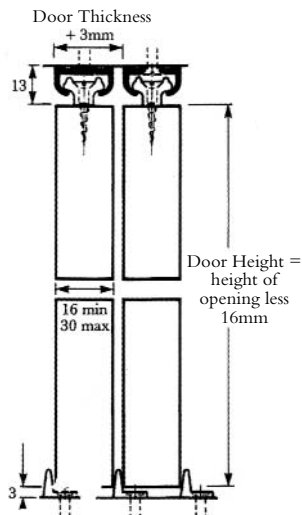

For lightweight wood or chipboard sliding doors eg. kitchens, bathrooms, serving hatches and built-in furniture where no bottom track is necessary. Silent and easy to fix, the doors can be simply removed when required.

KITS

Standard kits for 2 doors contain: 2 top aluminium tracks with fixing holes, 4 nylon sliders, safety stop, 2 flushpulls, screw-fixed nylon guides, all screws and fixing instructions. Lock available as optional extra. Bulk component packs also available.

INSTALLATION NOTES

(also see drawing)

For light, wood-framed or composition board doors up to 900mm wide and 9kg maximum weight (16-30mm thick). No bottom track is required and only 13mm headroom is needed.

Precision-made, satin-anodised finish aluminium gear for sliding glass doors for domestic and commercial displays, eg. bookshelves, cabinets and hatches. The silent top guide incorporates brushpile strips. The bottom roller incorporates a precision bearing unique to Henderson. Double or multiple lines of track can be fitted.

KITS

Standard kits for 2 doors contain: top guide, glazing strip, 2 glass rails, 4 nylon tyred bottom rollers, bottom rail, end caps, screws and fixing instructions.

OPTIONAL EXTRAS

Optional extras include: finger-pull (no.27) and cylinder lock (no. 507RH or 507LH) (see pp 52-57 for full product description). Bulk component packs are also available.

INSTALLATION NOTES

(also see drawing)

For standard 6mm glass, maximum weight 25kg (1m²) per panel, maximum width 900mm per panel (not less than half panel height).

For opening widths to	2 door kit no.
1200mm	Z12
1500mm	Z15
1800mm	Z18
Max leaf size	1m² (Max width 900mm)
Max leaf weight	25kg

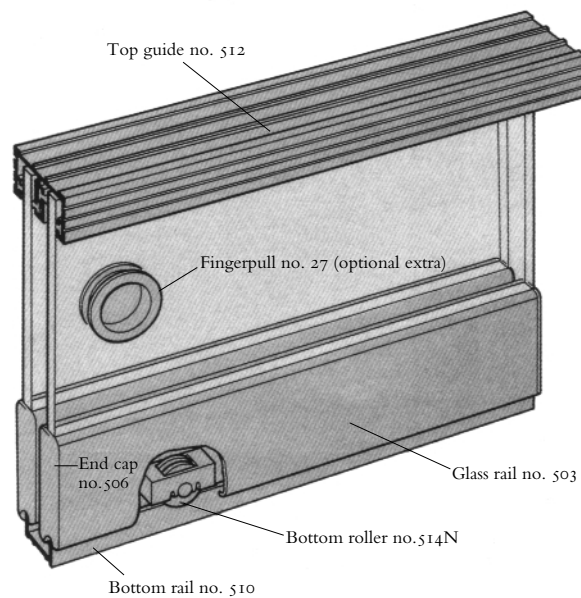

(See Component/Accessory pp 52-56 for product descriptions)

SOFFIT FIXED

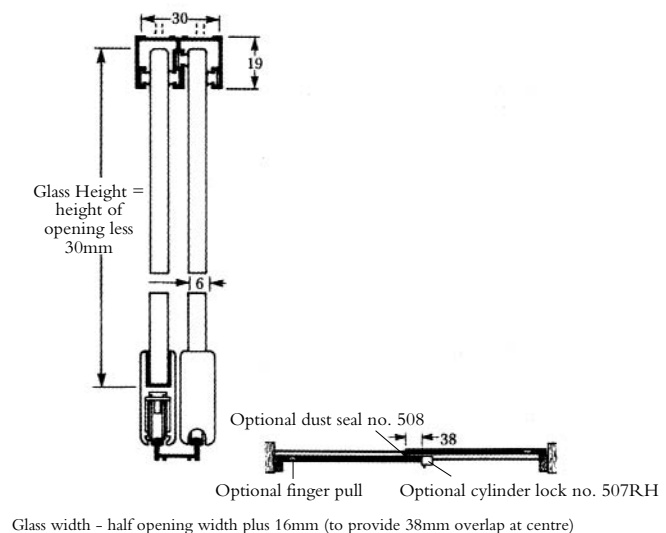

**FOR SLIDING
CABINET
DOORS TO 23KG**

LORETTO

For opening widths to	2 panel kit no.
1200mm	D4
1500mm	D5
1800mm	D6
Max leaf size	1800 x 900 x 45mm
Max leaf weight	23kg

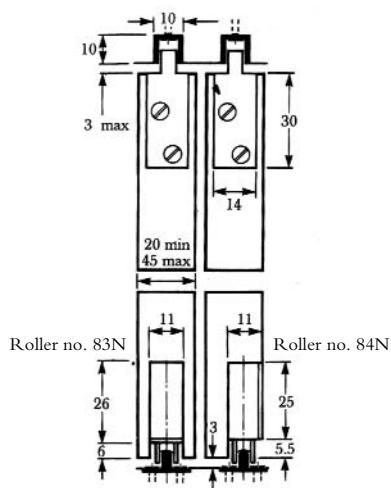
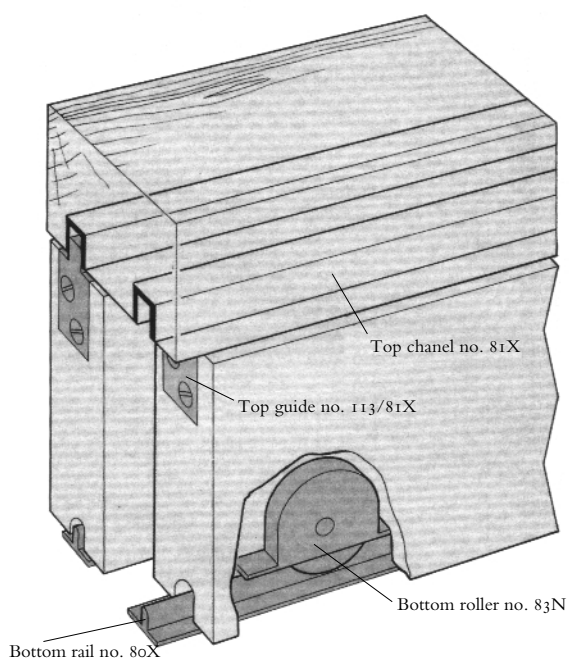

Aluminium top channels with nylon guides and aluminium bottom rails with nylon rollers for quiet, smooth operation of wood-framed glazed or flush, bi-passing cupboard or cabinet doors. Multiple tracks can be fitted.

KITS

Standard kits for two door panels contain 2 guide channels, 4 guides 4 bottom rollers, 2 rails, screws and fixing instructions.

OPTIONAL EXTRAS

Optional extras include: face-fix rollers no. 84N (2 per door) flushpull no. 400; lock no.291 (see pp 52-57 for full product description). Bulk components packs are also available.

INSTALLATION NOTES

(also see drawing)

Top guides mortised into door and guide channels mortised into soffit. Bottom rollers mortised into bottom rail of door (bottom rail must be of sufficient thickness - minimum 20mm). Butt joints on rail or channel are not recommended. Maximum panel weight 23kg, maximum door size 900mm wide by 20-45mm thick.

All dimensions in mm

An easy to fit kit for timber doors that requires no routing of the doors, as all components are surface mounted. Bottom rollers operate on aluminium rails producing a quiet, smooth operation.

KITS

Standard kits for 2 or 3 doors contain: aluminium rail, face-fixed nylon-wheeled bottom rollers, face-fixed nylon guides, screws and fixing instructions.

OPTIONAL EXTRAS

Optional extras include: fittings pack no. CI, flushpull no. 400 and semi-flush bolt no. 333. Bulk component packs are also available.

INSTALLATION NOTES

(Also see drawing)

For 2 and 3 door units with a maximum of 25kg door weight, width 920mm, height 2400mm and door thickness of 16mm - 40mm. Door construction must permit secure fixing of hanger plates. Butt joints on rail is not recommended.

For opening widths to	No. doors	Kit no.
1500mm	2	C15
1800mm	2	C18
2400mm	3	C24
Max leaf size	2400 x 920 x 40mm	
Max leaf weight	25kg	

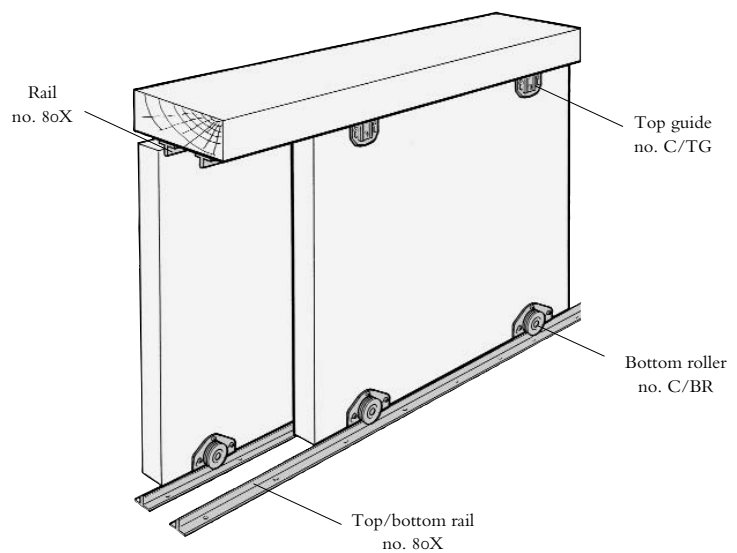

SOFFIT FIXED

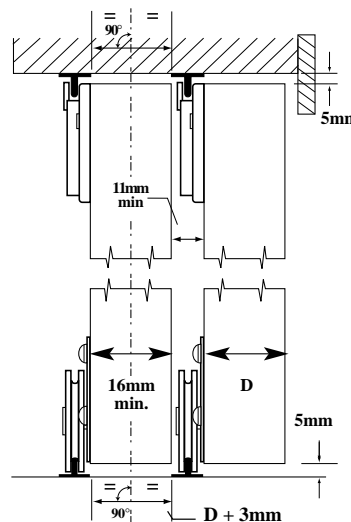

All dimensions in mm

FOR SLIDING DOORS TO 30KG

For single door opening widths to	Kit no.
900mm	SEN
Max leaf size	2400 x 900 x 35mm
Max leaf weight	30kg

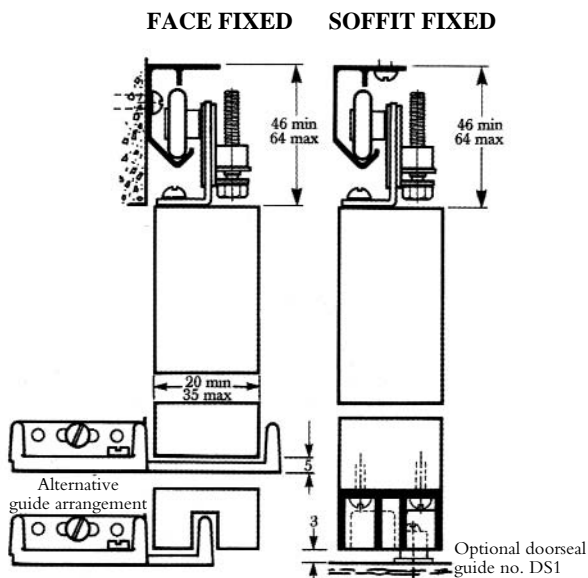
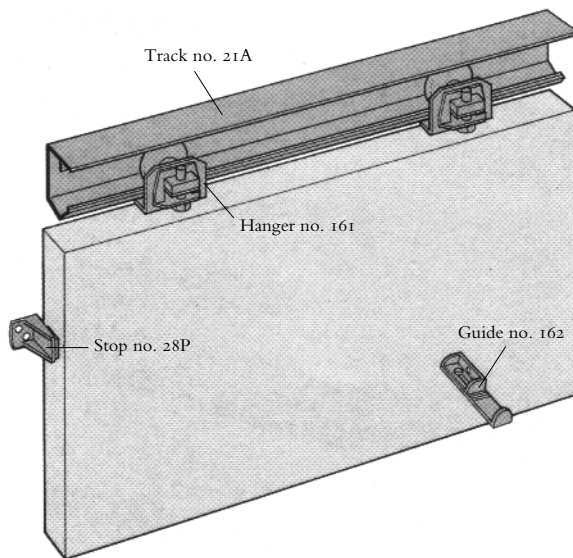

Easily fixed sliding doors for soffit or face fixing without drilling into door, and an easy-fix floor guide.

KITS

Standard kits for a single leaf door contain: jump-proof, face/soffit fixing aluminium track; nylon-tyred, ball-bearing, adjustable top fixing hangers; adjustable nylon guide; stop and fixing instructions.

OPTIONAL EXTRAS

Optional extras include:

anti-draught doorseal no. DS1; pelmet no. 40P and pelmet end caps (2 off) no. EC40P; flushpull no. 400; flushbolt no. 333; lock no. 295; door edge sponge strip no. 537 (see pp 52-57 for full product description). Bulk component packs are also available.

INSTALLATION NOTES

(also see drawing)

For a lightweight, wood framed door to maximum 30kg, maximum width 900mm and door thickness 20-35mm. Door construction must permit secure fixing of hanger plates.

All dimensions in mm

Easily installed, no-maintenance design for exceptionally quiet sliding doors, with optional kits for conversion to simultaneous action or self-closing doors.

KITS

Standard kits for a single leaf door contain: jump-proof track for face/soffit fixing; twin nylon-wheeled, low friction adjustable one piece hanger and fixing plates; adjustable nylon guide; stop and fixing instructions.

OPTIONAL EXTRAS

Optional extras include: self-closing system pulley assembly (advise leaf weight); simultaneous action unit (2 leaf doors) no. 23; anti-draught doorseal no. DS1; pelmet no. 40P and pelmet end caps (2 off) no. EC40P; flushpull no. 400; flush-bolt no. 333; lock no. 295; door edge sponge strip no. 537 (see pp 52-57 for full product description). Bulk component packs are also available.

INSTALLATION NOTES

(also see drawing)

For a wood door to maximum 45kg weight per leaf, width 610 min - 915mm max and door thickness 30-50mm. Door construction must permit secure fixing of hanger plates.

For single door width	Kit no.
610 - 915mm	P9
Max leaf size	2400 x 915 x 50mm (min width 610mm)
Max leaf weight	45kg

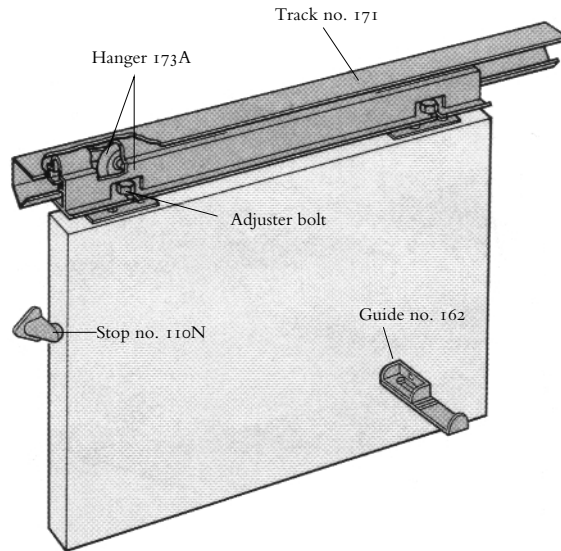

FACE FIXED

SOFFIT FIXED

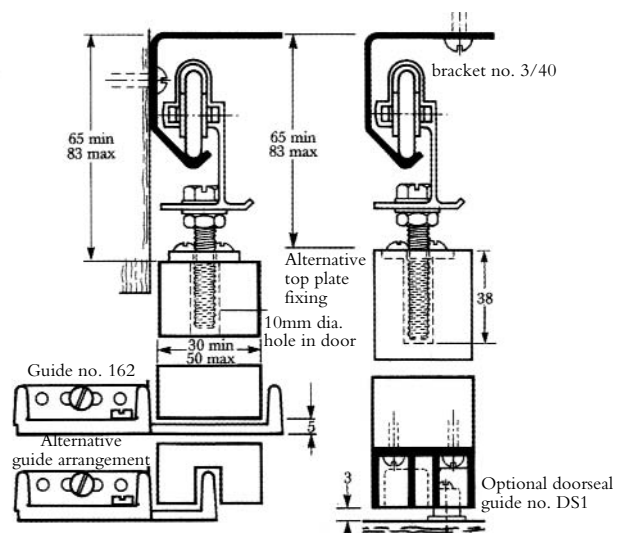

All dimensions in mm

**FOR SINGLE
TRACK SLIDING
WARDROBE
DOORS TO 45KG**

SINGLE TOP

For single door opening widths to	Kit no.
600mm	ST12
750mm	ST15
900mm	ST18
Max leaf size	2400 x 900 x 40mm
Max leaf weight	45kg

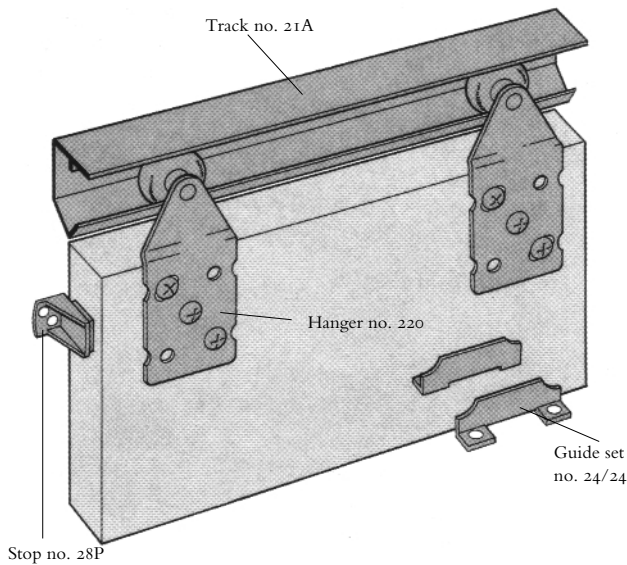

FACE FIXED

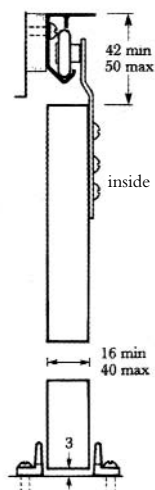

SOFFIT FIXED

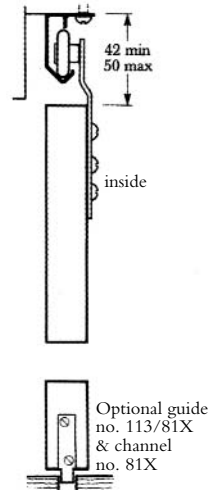

For a wide range of single leaf, wood or composite sliding doors, with face or soffit fixing top track and floor guides or optional bottom channel.

KITS

Standard kits for a single leaf door contain: jump-proof, face/soffit fixing aluminium section track; nylon-tired, face-fixing, ball-bearing hangers; nylon guides; rubber-buffered stop; screws and fixing instructions.

OPTIONAL EXTRAS

Optional extras include:

1-leaf fittings pack no. ST01; guide no. 113/81X (2 per door) and guide channel no. 81X; flushpull no. 400; lock no. 295; door edge sponge strip no. 537 (see pp 52-57 for full product description). Bulk component packs are also available.

INSTALLATION NOTES

(also see drawing)

For a single leaf door to a maximum 45kg weight, width to 900mm and thickness 16-40mm. For heavy use applications fit optional guide no. 113/81X and guide channel no. 81X.

All dimensions in mm

DOUBLE TOP

FOR DOUBLE TRACK SLIDING WARDROBE DOORS TO 45KG

For a wide range of double leaf, wood or composite sliding doors, with easy soffit fixing top track and floor guides or optional bottom channel.

KITS

Standard kits for 2 or 3 leaf units contain: jump-proof soffit fixing aluminium section track; nylon-tyred, face-fixing, ball-bearing hangers; nylon guides; rubber-buffered stop; screws and fixing instructions.

OPTIONAL EXTRAS

Optional extras include: fittings pack no. W01 (1 extra leaf), no. W02 (2 extra leaves); guide no. 113/81X (2 per door) and guide channel no. 81X; flushpull no. 400; reversible hangers no. 222; latch set no. 295; door edge sponge strip no. 537 (see pp 52-57 for full product descriptions). Bulk component packs are also available.

INSTALLATION NOTES

(also see drawing)

For 2 or 3 leaf units to a maximum 45kg weight per leaf, width to 900mm and thickness 16-40mm as standard. For heavy use applications fit optional guide no. 113/81X and guide channel no. 81X. For flexibility of layout in multi-leaf applications use reversible hangers. For triple line of doors fit additional Single Top system.

For opening widths to	No. leaves required	Kit no.
1200mm	2	W12
1500mm	2	W15
1800mm	2	W18
2400mm	3	W24
Max leaf size	2400 x 900 x 40mm	
Max leaf weight	45kg	

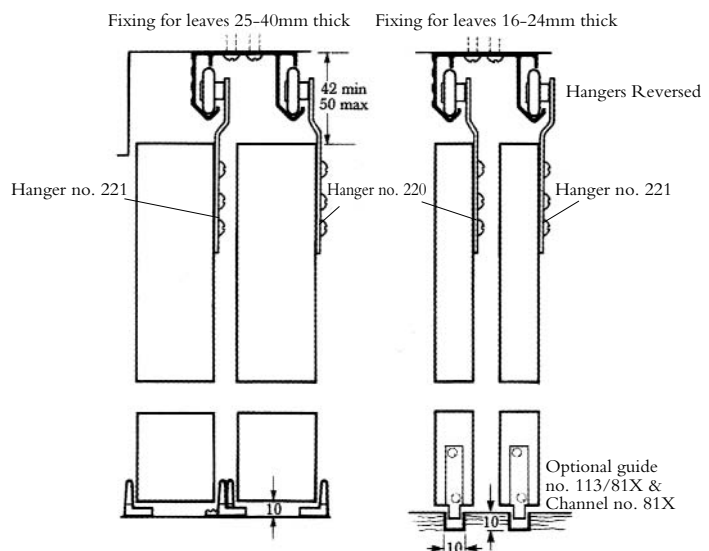
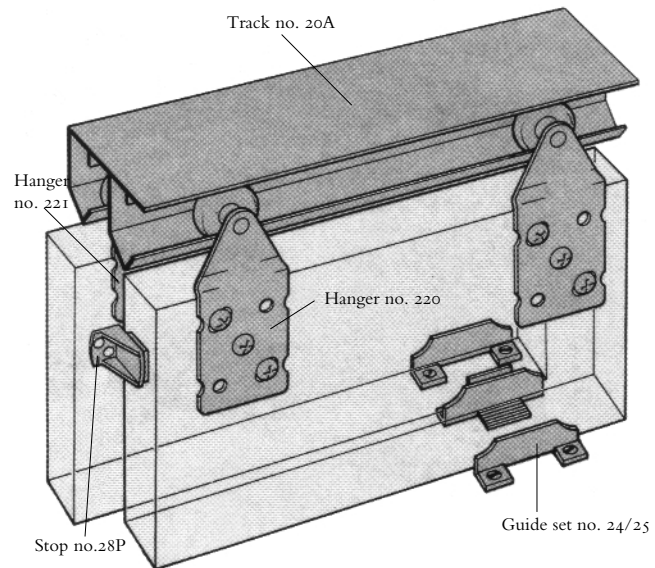

All dimensions in mm

**FOR FOLDING
WARDROBE
DOORS TO 14KG**

BIFOLD

For opening widths to	No. leaves required	Kit no.
1067mm	2	B10/2
1525mm	4 (2x2)	B15/4
2135mm	4 (2x2)	B20/4
Max leaf size	2400 x 530 x 35mm	
Max leaf weight	14kg	

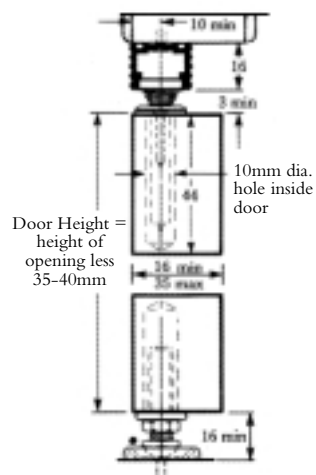
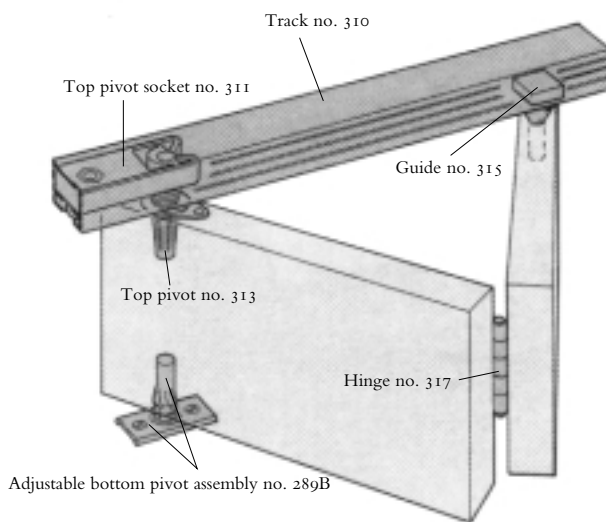

Easy-fit gear for wood or composite folding doors, with silent nylon spring-loaded guides in an aluminium top track. The spring-loaded end pivot arrangement allows leaves to fold completely flat for unhindered access to walk-in cupboards and wardrobes. No bottom track or door jamb required. Any number of two leaf units can be used for an opening, each anchored by top and bottom pivots.

KITS

Standard kits for 2 or 4 (2x2) leaves containing aluminium top track, nylon guides, pivots and sockets, bumper, hinges, aligner, screws, spanner and fixing instructions.

OPTIONAL EXTRAS

Optional extras include: 2-door fittings pack no. BF2, (see pp 52-57 for full product description). Bulk component packs also available.

INSTALLATION NOTES

(also see drawing)

For doors with maximum 14kg single leaf weight, maximum 530mm wide x 2400mm high in maximum opening height 2440mm. Top and bottom pivots and guide must be securely fixed into door rails - minimum thickness 16mm, maximum thickness 35mm. Adjustable bottom pivot for ease of fitting.

All dimensions in mm

HUSKY FOLDING 25

FOR FOLDING
DOORS AND
ROOM DIVIDERS
TO 25KG

For efficient and easy-to-use light folding doors, neatly stacking at one side and without floor guides for an uninterrupted run of carpet. For larger openings, a floor guide channel should be included. If doors are required to stack at both sides additional pivots are required. Soffit fixing only is available.

KITS

Kits HF25/12 and HF25/24 contain: top and bottom pivots for fixing into end panel; 4-wheeled adjustable nylon hangers; hinges; screws; fixing instructions and steel track no. 280.

FITTING PACKS

2 and 4 leaf fitting packs contain all the components contained in the kits except the track. Order also track no. 280 or aluminium section track no. 280A.

OPTIONAL EXTRAS

Optional extras include: set of 5 brackets no. 2815; guide no. 106HF/94; channel no. 94X; flush-bolt no. 333; flushpull no. 400 (see pp 52-57 for full product description). Bulk component packs are also available.

INSTALLATION NOTES

(also see drawing)

For panels with maximum single weight 25kg, maximum dimensions 600mm wide x 2400mm high and thickness 20-40mm; 12 panels (6 each side) maximum. For panels in excess of 15kg, 450mm wide or for 4 or 6 panel units, a floor guide channel

For opening widths to	No. panels	Kit no.	Channel required
1200mm	2	HF25/12	1 x 1.2m
2400mm	4	HF25/24	1 x 2.4m
Max leaf size		2400 x 600 x 40mm	
Max leaf weight		25kg	

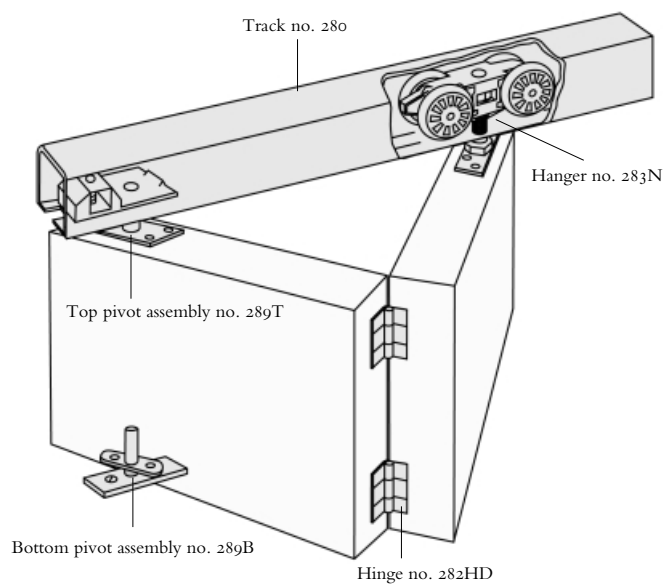

SOFFIT FIXED

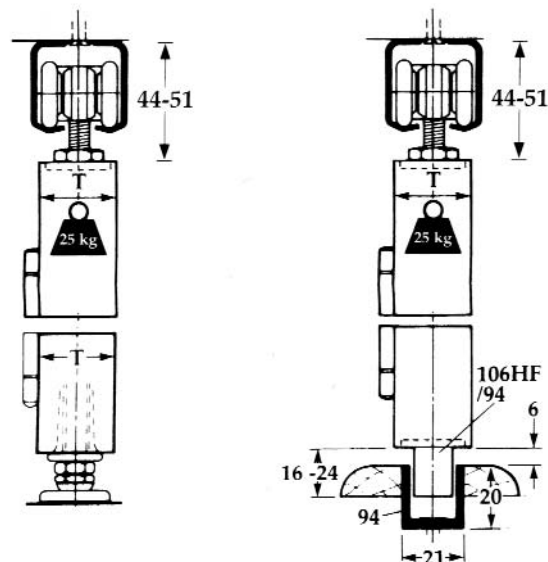

Optional guide channel

All dimensions in mm

**FOR FOLDING
DOORS AND
ROOM DIVIDERS
TO 40KG**

HUSKY FOLDING 40

For opening widths to	No. panels	Kit no.
1500mm	2	HF40/15
3000mm	4	HF40/30
Max leaf size	2400 x 750 x 40mm	
Max leaf weight	40kg	

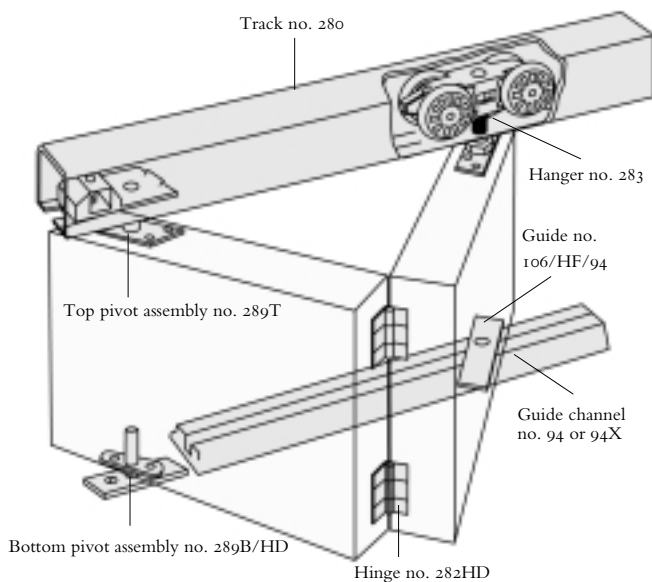

(See Component/Accessory pp 52-56 for product descriptions)

SOFFIT FIXED

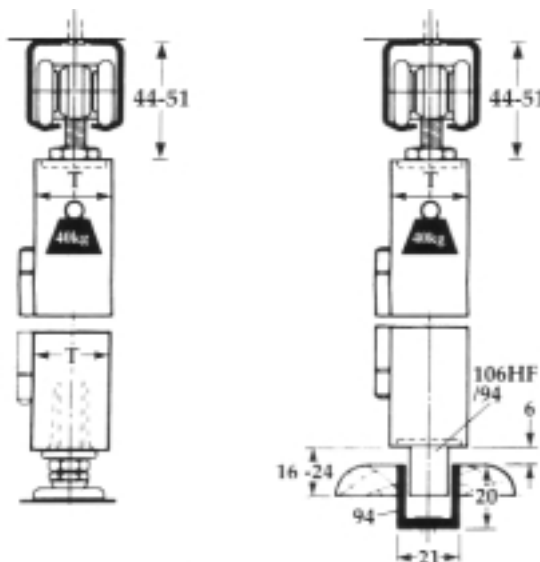

All dimensions in mm

For efficient and easy-to-use medium weight folding doors, neatly stacking at one side. If doors are required to stack at both sides additional pivots are required. Soffit fixing only is available.

KITS

Kits HF40/15 and HF40/30 contain: top and bottom pivots for fixing into end panel; 4 nylon bodied, needle roller bearing hangers with top plate; hinges; roller guides no.106/HF/94; screws; fixing instructions, steel track no. 280 and guide channel no. 94X.

FITTING PACKS

2 and 4 leaf fitting packs contain all the components contained in the kits except the track. Order also track no. 280 or aluminium section track no. 280A. Guide channel no.94 or 94X should be separately ordered to the same length as the track.

OPTIONAL EXTRAS

Optional extras include: flushbolt no. 333; flushpull no. 400 (see pp 52-57 for full product description). Bulk component packs are also available.

INSTALLATION NOTES

(also see drawing)

For panels with maximum single weight 40kg, maximum dimensions 750mm wide x 2400mm high and thickness 20-40mm; 12 panels (6 each side maximum). Roller guides should be fitted to alternate panels (see drawing) to run in the guide channel.

HUSKY 50

FOR SLIDING
WOOD DOORS
TO 50KG

Reliable and highly versatile gear using precision-made components for trouble-free operation.

KITS

Husky 50: kits for single wood doors to 50kg max. weight contain: pre-drilled track; face-fixing brackets; 2 nylon bodied, acetal wheel hangers; nylon guide; stops and fixing instructions. Single door fittings only pack H50N also available.

OPTIONAL EXTRAS

Optional extras include: face-fixing brackets packs no. 2815 (5 brackets); no. 2818 (8 brackets); hanger for metal doors no. 285N; roller guide no. 106R/94; aluminium floor channel no. 94X; bow handle no. 863; flushpull no. 414; flushpull no. 400; flushbolt no. 333; lock no. 295; door edge sponge strip no. 537; anti-draught doorseal guide no. DSI (see pp 52-57 for full product description). Bulk component packs are also available.

Max leaf size	Weight	Kit no.
2400 x 800 x 50mm	50kg (wood)	Husky H50/15
2400 x 950 x 50mm	50kg (wood)	Husky H50/18
2400 x 1050 x 50mm	50kg (wood)	Husky H50/20
2400 x 1250 x 50mm	50kg (wood)	Husky H50/24

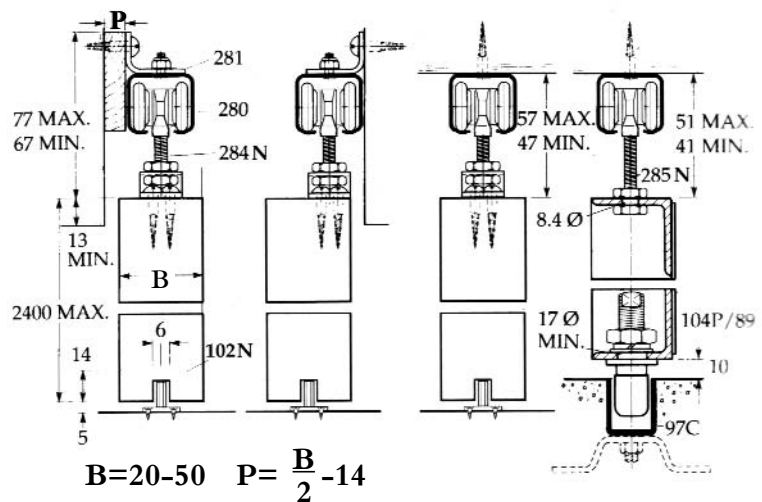
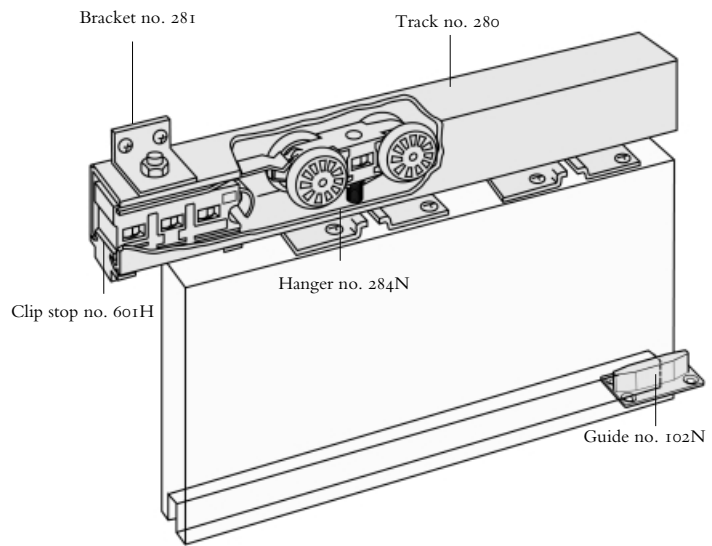

All dimensions in mm

Aluminium track kits, clip on aluminium fascia's and sliding glass door kits now also available.

**FOR SLIDING
WOOD OR
METAL DOORS
TO 100KG**

HUSKY 100

Max leaf size	Weight	Kit no.
2400 x 800 x 50mm	100kg (wood or metal)	Husky H100/15
2400 x 950 x 50mm	100kg (wood or metal)	Husky H100/18
2400 x 1050 x 50mm	100kg (wood or metal)	Husky H100/20
2400 x 1250 x 50mm	100kg (wood or metal)	Husky H100/24

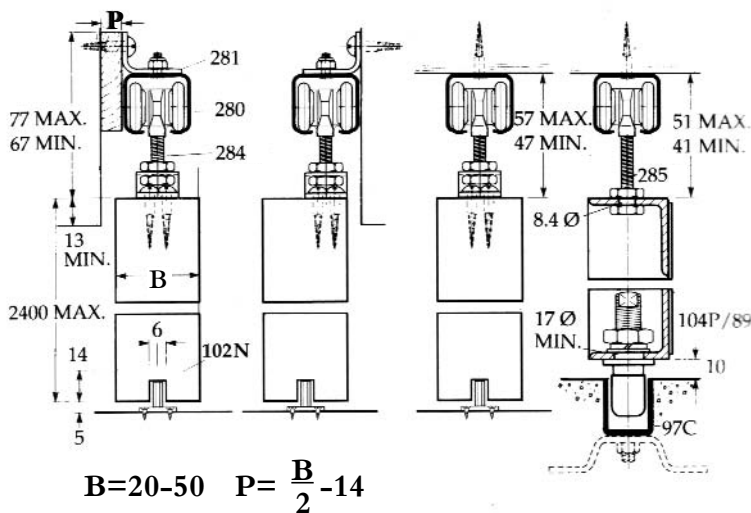
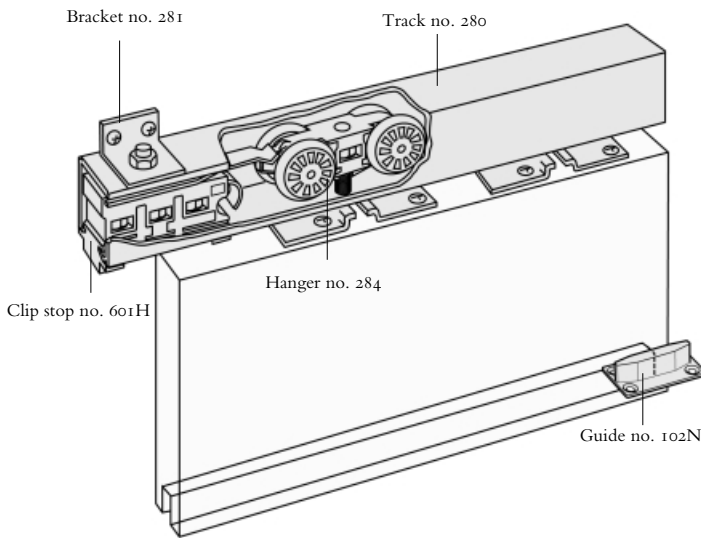

Reliable and highly versatile gear using precision-made components for trouble-free operation.

KITS

Husky 100: single door fittings pack H100 for metal or wood doors to 100kg max. weight contain: 2 nylon bodied, needle roller bearing 4-wheel hangers; nylon guide; clip stop 601H to hold door fully open or closed and fixing instructions. Track no. 280 (steel) or no. 280A (aluminium) supplied separately in standard lengths from 1.2m to 4.0m.

OPTIONAL EXTRAS

Optional extras include: face-fixing bracket packs no. 2815 (5 brackets); no. 2818 (8 brackets); hanger for metal doors no. 285; roller guide no. 106R/94; aluminium floor channel no. 94X; bow handle no. 863; flushpull no. 414; flushpull no. 400; flushbolt no. 333; lock no. 295; door edge sponge strip no. 537; anti-draught doorseal guide no. DSI (see pp 52-57 for full product description). Bulk component packs are also available.

All dimensions in mm

Aluminium track kits, clip on aluminium fascias and sliding glass door kits now also available.

MARATHON 55 & 90

**FOR SLIDING
DOORS TO 55KG
AND 90KG**

For heavily used timber or metal doors, offering smooth and reliable action due to its precision engineering, solid alloy runner bar and one piece ball cage design.

KITS

Single door kits for max. door weights of 55kg and 90kg contain: top assembly (track, hanger plates, ball cage and runner bar); 2 nylon top plates (with integral buffer); wall mounted stops; nylon floor guide (guide channel to be mortised into door bottom rail).

OPTIONAL EXTRAS

Optional extras include: soffit brackets (5 off) no. 3/40; self-closing system pulley assembly SCK1 (advise door weight); biparting unit (2 doors each max 900mm) no. 23; anti-draught doorseal no. DSI; pelmet no. 40P and pelmet end caps (2 off) no. EC40P; flushpull no. 400; flushbolt no. 333; lock no.s 294, 295; door edge sponge strip no. 537 (see pp 52-57 for full product description). Bulk component packs are also available.

INSTALLATION NOTES

(also see drawing)

For internal fitting, or external with adequate protection for gear, can be face or soffit fixed. Bi-parting gear can be fitted to operate both doors simultaneously, and a self-closing pulley system is also available.

For door opening widths	Junior kit 55kg	Senior kit 90kg
400-750mm	J2	
750-900mm	J3	S3
900-1050mm	J4	S4
1050-1200mm	J5	S5
1200-1500mm	J6	S6
Max leaf size	3000 x 1500 x 50mm	

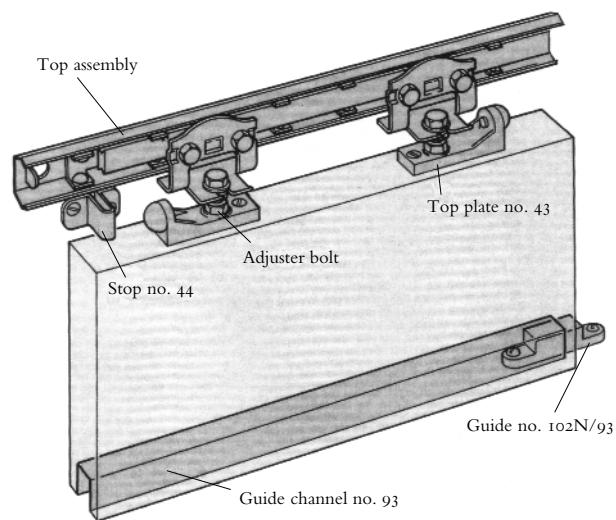

(See Component/Accessory pp 52-56 for product descriptions)

FACE FIXED

SOFFIT FIXED

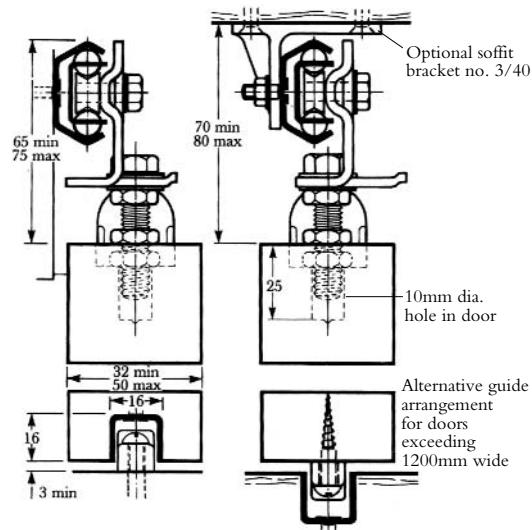

All dimensions in mm

**FOR SLIDING
FIRE DOORS
TO 90KG**

MARATHON FIRE DOOR

For door opening widths	Gear Kit no.
750-900mm	S3
900-1050mm	S4
1050-1200mm	S5
1200-1500mm	S6
Fire door kit	FDK1
Max leaf size	3000 x 1500 x 50mm (min width 750mm)
Max leaf weight	90kg

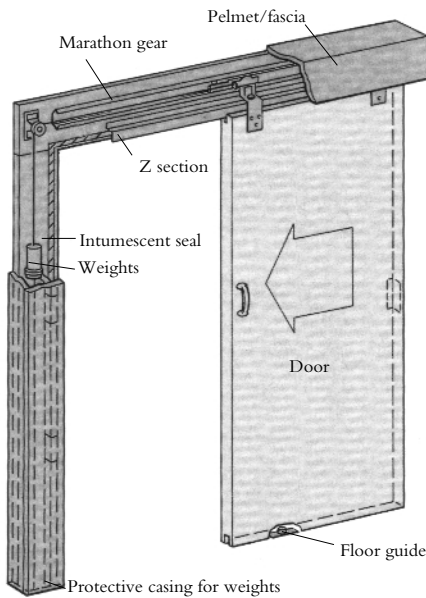

Typical installation

For door opening widths	Gear Kit no.	Thickness
750-900mm	S3	32 - 50mm
900-1050mm	S4	32 - 50mm
1050-1200mm	S5	32 - 50mm
1200-1500mm	S6	32 - 50mm

For door sizes over 90kg or above 1500mm wide or below 750mm wide consult PC Henderson

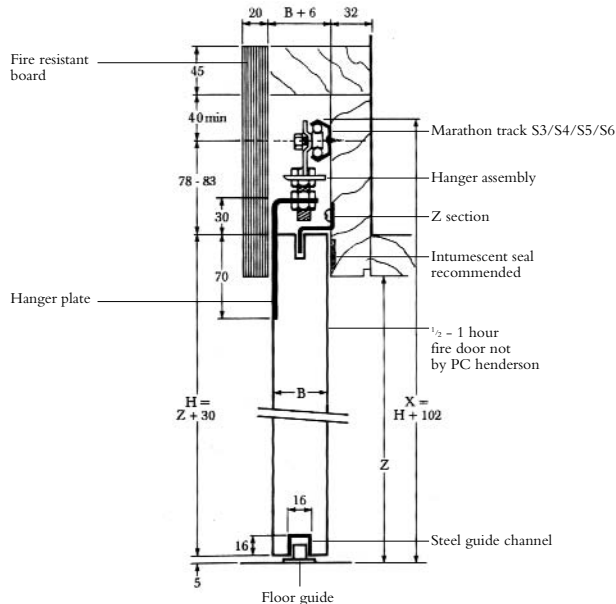

All dimensions in mm

For sliding fire doors offering a smooth, secure automatic closing action due to action of the counterbalancing weights.

KITS

The kit is designed for single doors up to 90kg and between 750mm and 1500mm wide, and must be used in conjunction with an S3,S4,S5 or S6 Marathon sliding gear kit. For doors above or below these limits, please contact the Technical Department at PC Henderson.

NB.

It is recommended that intumescent fire seals be incorporated into the door framework to contain the fire within the fire area. (Smoke seals hinder the self-closing action of the door so should not be used.) Seals are not supplied by PC Henderson.